

# HD Type Carburettor: Routine Servicing

## Jet centering

The piston should fall freely onto the carburettor bridge with a click when the lifting pin is released with the jet in the fully up position. If it will only do this with the jet lowered then the jet unit requires re-centering. This is done as follows:

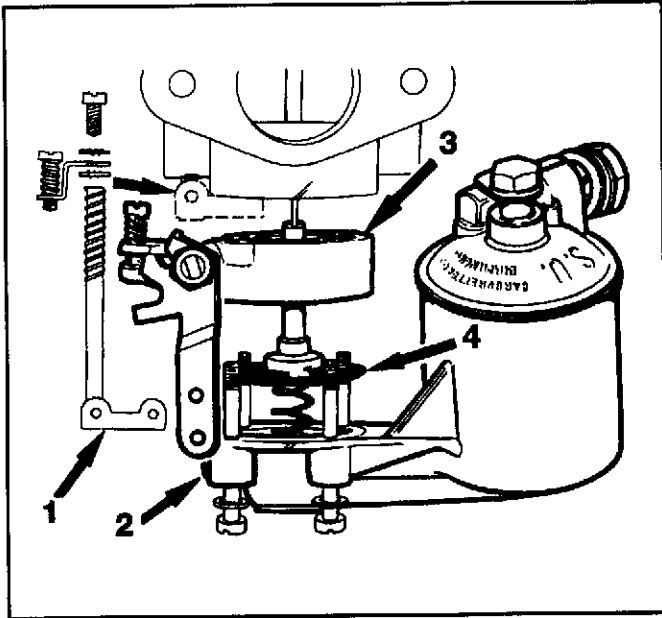

**1**

- Mark the position of the jet housing and float-chamber in relation to the carburettor body for reassembly.
- Remove the plate retaining screw and withdraw the cam rod assembly (1).
- Unscrew and remove the float-chamber securing screws.
- Remove the float-chamber (2) and the jet housing (3) and then release the jet assembly (4).

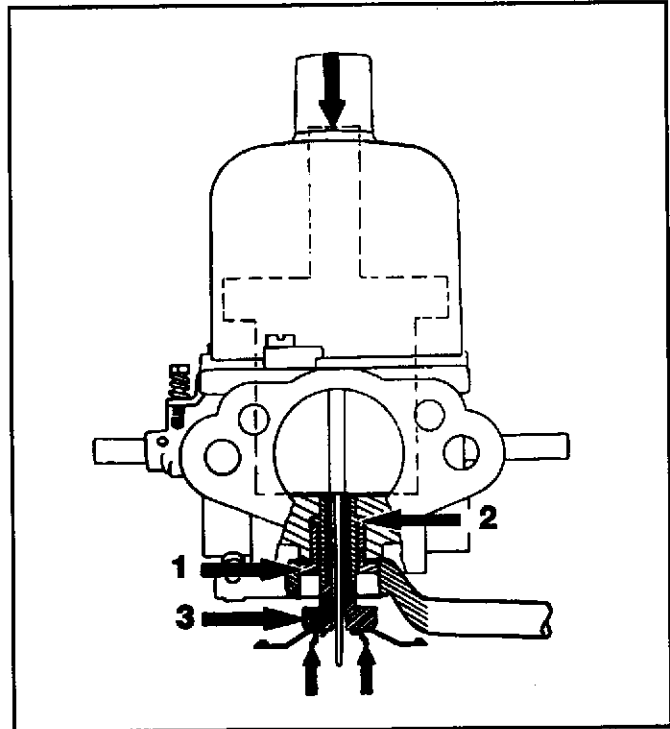

**2**

- Slacken the jet locking nut (1), using a ring spanner, until the jet bearing (2) is just free to move.
- Remove the piston damper, hold the jet (3) in the 'fully up' position and apply light pressure to the top of the piston rod. Tighten the jet locking nut (1).
- Check again as in item 1 and ensure that the jet moves down the bearing freely.
- Reassemble, ensuring that the jet and diaphragm are kept to the same angular position and that the beaded edge of the diaphragm is located in the housing groove.
- Refill piston damper with oil (see tuning section).