

Sprinter Mobil 3000

Automotive lift date: 07/2008
Manual date: 07.07.2008

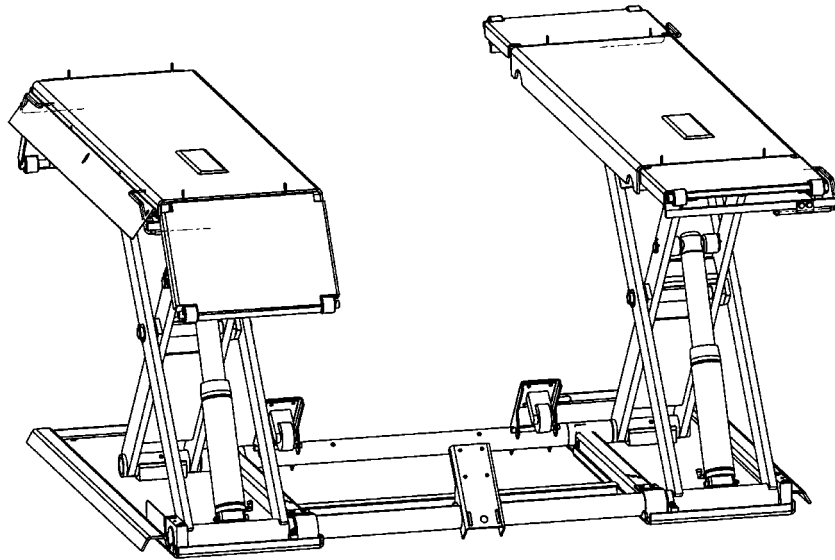

Operating Instruction and Documentation

Serial number:.....

Retailer address / phone



Nussbaum

Otto Nußbaum GmbH & Co.KG//Korker Strasse 24//D-77694 Kehl-Bodersweier
Tel: +49(0)7853/8990 Fax: +49(0)7853/8787
E-mail: info@nussbaum-lifts.de//<http://www.nussbaum-lifts.de>

Contents

Foreword	3
Record of installation	5
Record of handing over	6
1. Introduction	7
1.1 Installation and check of the automotive lift	7
1.2 Information of Warning	7
2. Master document of the automotive lift	8
2.1 Lift–manufacturer	8
2.2 Application	8
2.3 Changes at the construction	8
2.4 Displacement of the automotive-lift	8
2.5 Declaration of conformity	9
2.6 Drive on directions	10
3. Technical Information	13
3.1 Technical ratings	13
3.2 Data sheet	14
3.3 Hydraulic diagram drawing	15
3.4 Electric diagram	16
4. Safety regulations	21
5. Operating instructions	22
5.1 Lifting the vehicle	22
5.2 Lowering the vehicle	23
5.3 Change the installation place	23
6. Troubleshooting	23
7. Inspection and Maintenance	25
7.1 Maintenance plan of the lift	25
7.2 How often must the lift be cleaned?	26
8. Security check	27
9. Installation	27
9.1 Regulations	27
9.2 Initiation	28
9.3 Change the installation place	28
First security check before installation	31
Regular security check and Maintenance	32
Extraordinary security check	40

Foreword

Nußbaum lifting systems are the result of a long time experience in the automotive lifting industry. The high quality and the superior concept ensure reliability, a long lift lifetime and above all and economic business solution.

To avoid unnecessary damage, injury or even death, read the operating instructions with care and observe the contents.

Nußbaum lifts is not responsible for incidents involving the use of Nußbaum lifting systems for applications other than those for which they were designed.

Otto Nußbaum GmbH & Co.KG is not liable for any resulting damages. The user carries the risk alone.

Obligations of the user:

- To observe and adhere to the operating instructions.
- To follow the recommended inspection and maintenance procedures and carry out the prescribed tests.
- The operating instructions must be observed by all persons working with or around the lift.
- Above all chapter 4 "Safety Regulations" is very important and must be closely adhered to.
- In addition to the safety regulations stated in the operating instructions manual, the appropriate safety regulations and the operating procedures of the place of operation must also be considered.

Obligations of the operator:

The operator is obliged to allow only those persons complying to the following requirements to work with or around the unit.

- Persons being familiar with the basic regulations concerning labour safety and accident prevention and being trained to operate the particular unit.
- Persons having read and understood the chapter concerning safety and warning symbols.
- Persons using the lift are required to confirm that they have read and understood the chapter on safety and warning symbols by signing the appropriate form.

Dangers when operating the lift:

Nußbaum-Lifts are designed and built according to technical standards and the approved regulations for technical safety. The use of Nußbaum lifts for purposes other than those for which they were designed, may result in injury or even death.

The lift must only be operated :

- For its appropriate use
- In faultless condition concerning technical security.

Organisational Requirements:

- The instructions for use, are to be kept at the place of operation being easily access able at any time.
- In addition to the instructions for use, rules pertaining to other regulations i.e. accident prevention and environmental rules are to be observed and adhered to.

- The owner of the Nußbaum lifting system must ensure that operators and persons working with or around the lift occasionally conduct “refresher” courses to ensure that the appropriate operating procedures and safety precautions are known.
- Personal Protective Equipment (PPE) must be used according to the appropriate regulations.
- All safety- and danger signs on and around the lift are to be observed and followed!
- Spare parts must comply with the technical requirements specified by the manufacturer. This is only warranted with original parts.
- Observe and adhere to the specified time intervals between tests and inspections.

Maintenance works, repairing faults

- Adjustments, maintenance, and inspections, are to be followed according to the time intervals specified. Details regarding the exchange of parts and components as mentioned in the operating instructions are to be adhered to.
These works must only be carried out by expert personal.
- After maintenance- and repair works loose screws, nuts and bolts must always be firmly tightened!

Guarantee and liability

- Our “General conditions of selling and delivering” are in force.
There will be no guarantee or liability for incidents involving injuries or death or damage to equipment if these incidents are the result of one or more of the following reasons.
- Inappropriate use of the lift
- Inappropriate installation, initiation, operation and maintenance of the lift.
- Use of the lift while one or several security devices do not work, do not work correctly or are not installed correctly.
- Failure to follow the regulations of the operating instructions regarding transport, storage, installation, initiation, operation and maintenance of the lift.
- Unauthorized changes to the structure of the lift without first asking the producer.
- Unauthorized changes of adjustments of important components of the lift (e.g. driving elements, power rating, motor speed, etc)
- Wrong or incorrect maintenance practice.
- Catastrophes, acts of God or external reasons.

Initiation

The Sprinter Mobil was checked by Nußbaum Company. Before the first initiation the test must not additional take through by an expert.



Filling out and undersigned and copying this sheet and send the original to the lift manufacturer. The copy remains in the Manual.

Otto Nußbaum GmbH & Co.KG
Korker Strasse 24
77694 Kehl-Bodersweier
Germany

Record of installation

The automotive lift with the

Serial number:..... was installed on:.....

at the firm:..... at:.....

the safety was checked and the lift was started.

The installation was effected from the operating authority/competent (please delete as applicable).

The safety of the automotive lift was checked from the competent before the initial operation.

The operating authority attest the installation of the automotive lift, the competent attest the correct initial operation.

.....
date name of the operating authority signature of the operating authority

.....
date name of the competent person signature of the competent person

Your customer service:.....

To be completed only when the lift is fasten on the concrete.

Used anchor(*):.....(Type/Name)

Min. anchorage depth (*) observed: _____mm ok

Min. torque moment (*) observed: _____NM ok

(* see the description of the anchor manufacturer

Automotive lift date: 07/2008 / Manual date: 07.07.2008

Record of handing over

The automotive lift with the

Serial number:..... was installed on:.....

at the firm:..... at:.....

the safety was checked and the lift was started.

The persons below were introduced after the installation of the automotive lift. The introduction was carried out from an erector of the lift-manufacturer or from a franchised dealer (competent person).

..... date name signature
---------------	---------------	--------------------

..... date name signature
---------------	---------------	--------------------

..... date name signature
---------------	---------------	--------------------

..... date name signature
---------------	---------------	--------------------

..... date name signature
---------------	---------------	--------------------

..... date name signature
---------------	---------------	--------------------

..... date name of competent signature of the competent
---------------	----------------------------	-------------------------------------

Your customer service:.....

1.Introduction

The document "**Operating Instructions and Documentation**" contains important information about installation, operation and maintenance of the automotive lift.

To furnish proof of **installation of the automotive lift** the form "Record of Installation" must be signed and returned to the manufacturer.

To furnish proof of the singular, felt this documentation contains forms. The forms should be used to document the checks. They should not be removed from this documentation.

Every **Changes to the construction** and **displacement** of the automotive lift must be registered in the "**Master document**" of the lift.

1.1 Installation and check of the automotive lift

Only specialist staff is allowed to do work concerning safety and to do the safety checks of the lift.

They are called experts and competent person in this document.

Experts are persons (for example self-employed engineers, experts), which have received instruction and have experience to check and to test automotive lifts. They know the relevant labour and accidents prevention regulations.

Competent person are persons who have acquired adequate knowledge and experience with automotive lifts. They took part in training from the lift-manufacturer (servicing technicians of the manufacturer or dealer, are competent)

1.2 Information of Warning

To show danger and to show important information the three symbols below are used. Pay attention to those passages, which are marked with these symbols.



Danger! This sign indicates danger to life. Inexpert handling of the described operation may be dangerous to life.



Caution! This sign cautions against possible damage to the automotive lift or other material defects in case of inexpert handling .



Attention! This sign indicates for an important function or other important notes.

2. Master document of the automotive lift

2.1 Lift–manufacturer

Otto Nußbaum GmbH & Co. KG
Korker Straße 24
D-77694 Kehl-Bodersweier

2.2 Application

The automotive lift Sprinter Mobil 3000 is a lifting mechanism for lifting motor vehicles with a laden weight of up to 3000 kg. The max. Load distribution is 3:2 in or against drive-on direction. The automotive lift is only designed for servicing vehicles.

It's not allowed to install the standard-automotive lift in a hazardous location or washing bays. The lift is not equipped for climbing the platform. It is not allowed to carry persons with the lift. The automotive lift is flexible. You can change the position; every solid and level surface is suitable as location. The lift can be fastened on the floor with dowels. Important: You must distinguish between the vehicle with rear drive and front drive. (See next pages)

2.3 Changes at the construction

Changes at the construction, expert checking, resumption of work (date, kind of change, signature of the expert)

.....
.....
.....
.....

name, address of the expert

.....
place, date

.....
signature of the expert

2.4 Displacement of the automotive-lift

Displacement of the automotive-lift, expert checking, resumption of work (date, kind of change, signature of the competent)

.....
.....
.....
.....

name, address of the competent

.....
place, date

.....
signature of the competent

2.5 Declaration of conformity

EG- Konformitätserklärung



gemäß Maschinenrichtlinie Anhang II 1A

Declaration of Conformity according Machinery Directive 2006/42/EG ANNEX II 1A
Déclaration de conformité selon directive machines annexe II 1A
Declaración de conformidad según Directiva Maquinaria 2006/42/EG ANNEX II 1A
Dichiarazione di conformità in accordo alla direttiva 2006/42/EG ANNEX II 1A

Hiermit erklären wir, daß die Hebebühne, Modell:
Hereby we declare that the lift model:
Par la présente nous déclarons que le pont élévateur modèle:
Por la presente declara, que el elevador modelo:
Con la presente si dichiara che il sollevatore:

SPRINTER
SPRINTER EXPRESS MOBIL II
SPRINTER MOBIL 3000
SPRINTER NT

allen einschlägigen Bestimmungen der folgenden Richtlinien entspricht:
fulfils all the relevant provisions of the following Directives:
correspond aux normes suivantes:
cumple todas las disposiciones pertinentes de las Directivas siguientes:
adempie a tutte le richieste delle seguenti direttive:

Maschinenrichtlinie / Machinery Directive
EMV Richtlinie / EMC Directive

2006/42/EG
2004/108/EG

in Übereinstimmung mit den folgenden harmonisierten Normen gefertigt wurde
was manufactured in conformity with the harmonized norms
fabriqué en conformité selon les normes harmonisées en vigueur.
producido de acuerdo a las siguientes normas armonizadas.
è stato fabbricato in conformità con le norme armonizzate

Fahrzeug- Hebebühnen / Vehicle lifts
Elektromagnetische Verträglichkeit / Electromagnetic compatibility (EMC)

EN 1493: 2010
EN 61000-6-2 ,-6-4

Beauftragter für die Technische Dokumentation
Authorised to compile the technical file

Otto Nußbaum GmbH & Co. KG

Seriennummer
Serial number

.....
Seriennummer

Kehl- Bodersweier, 12.03.2012

.....
Hans Nußbaum

Doc. SPRINTER_2012-03.doc



Otto Nußbaum GmbH & Co. KG · Körker Str. 24 · D-77694 Kehl-Bodersweier
Tel.: +49(0)7853/899-0 · Fax: +49(0)7853/8787 · www.nussbaum-lifts.de



2.6 Drive on directions

Front drive vehicle

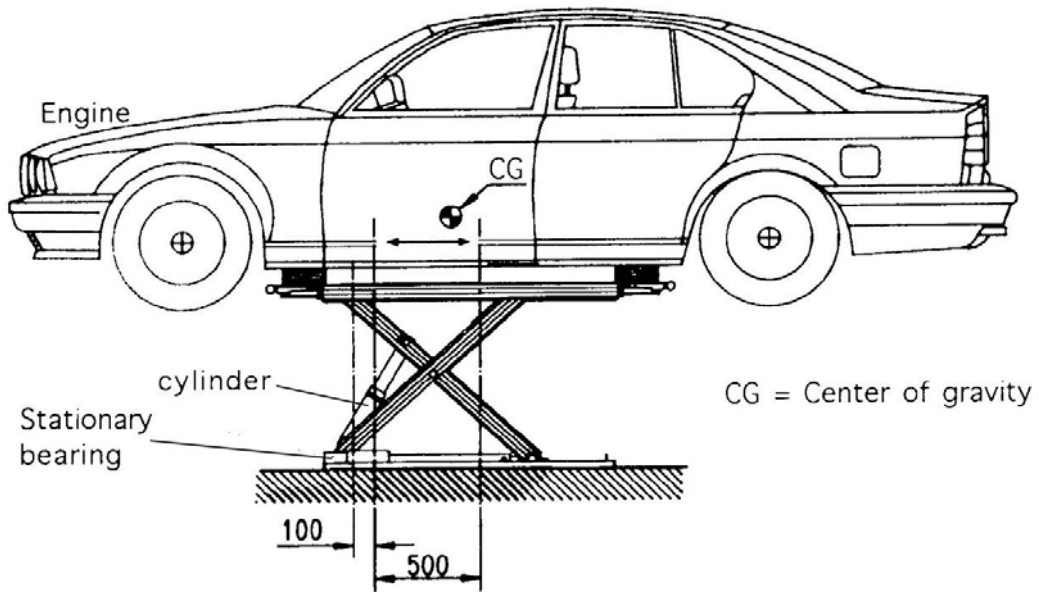

The center of gravity of the vehicle including load must be between 100 mm and 600 mm from the stationary bearing to wards the middle of the lift

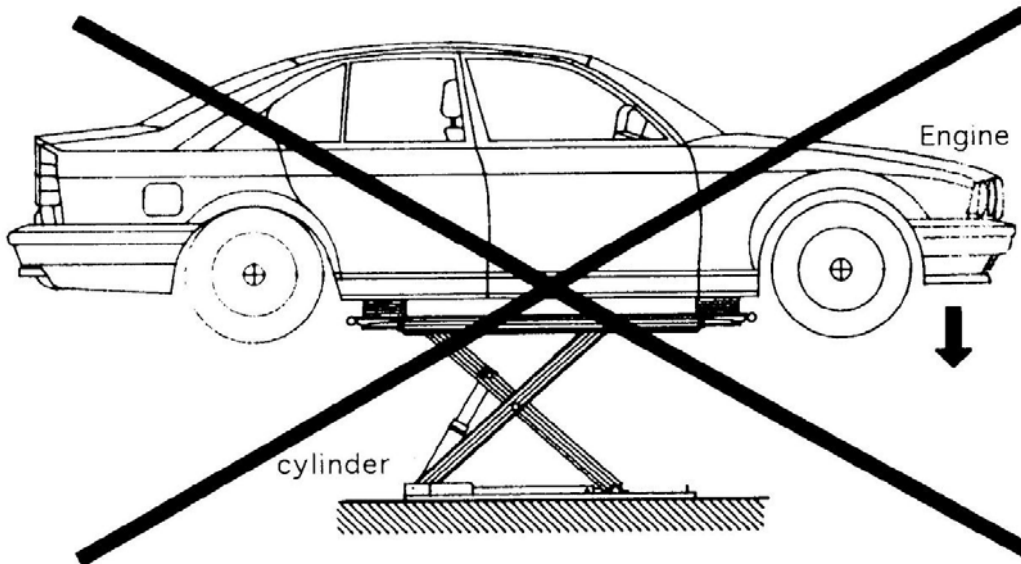

subject to alterations

rear drive vehicle

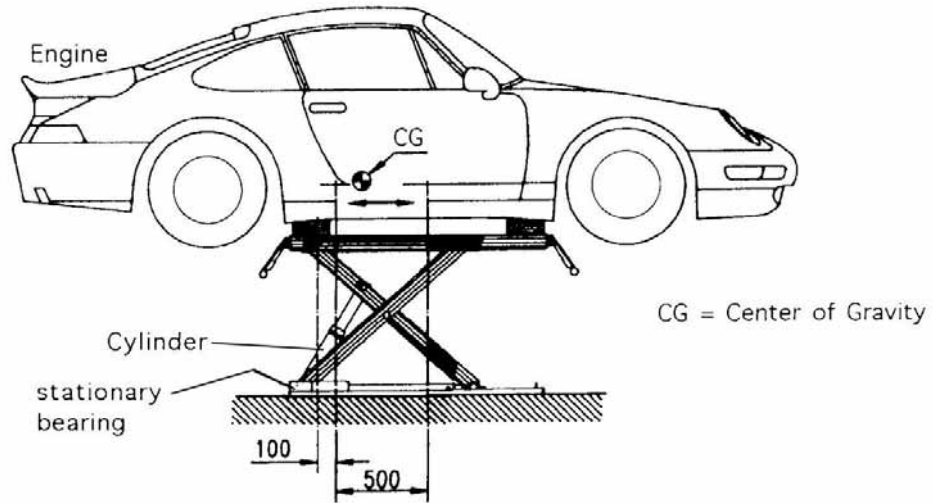

The center of gravity of the vehicle including load must be between 100 mm and 600 mm from the stationary bearing to wards the middle of the lift

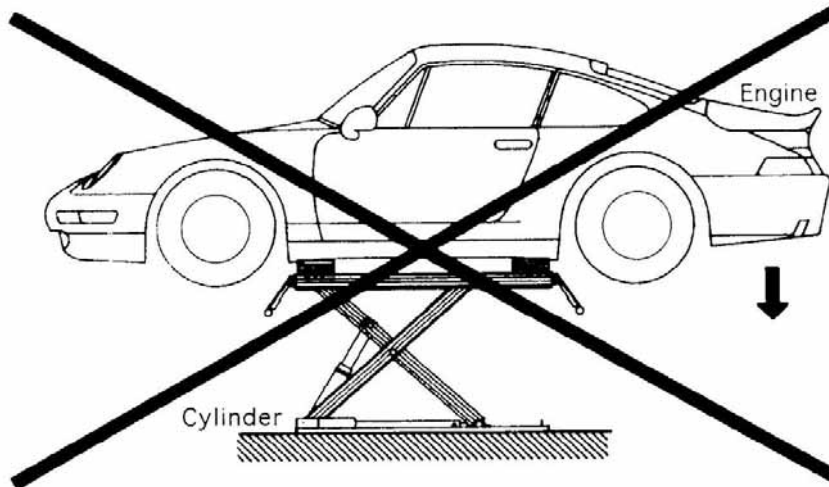

subject to alterations

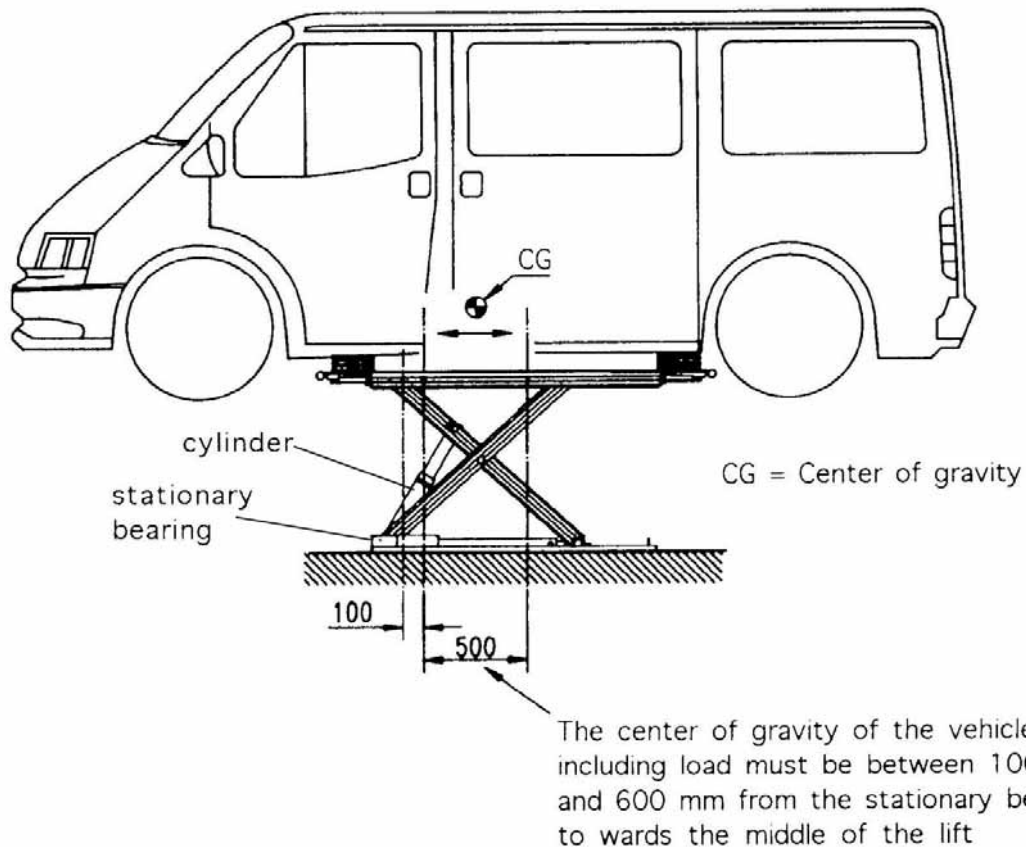

Piece of advice



The motor of the vehicle must be always located on the stationary bearing, otherwise the vehicle can fall down.



The centre of gravity of the vehicle including load must be between 100 mm and 600 mm from the stationary bearing to wards the middle of the lift.

3. Technical Information

3.1 Technical ratings

Capacity:	3000 kg
Load distribution:	3:2 in or against drive-on direction (Observe the centre of gravity of the lift)
max height:	max. 980 mm
Lifting time:	approx. 11 sec without load
Lowering time:	approx. 35 sec without load
Hydraulic pressure	approx. 230 bar
Pressure relief valve	approx. 260 bar
Oil tank	approx. 8 Litre
Sound level	≤ 75 dB(A)
Connection by customer	3~/N+PE, 400V, 50 Hz Standard Version with fuse 16 Ampere time lag (Pay attention to the tension of your country)

3.2 Safety device

1. Flow control valve
Safety device against over-rapid raising or lowering
2. Pressure relief valve
Overprint-safety of the hydraulic system
3. Foot protector
Safety device against squeeze
4. Lockable main switch
Safety device against unauthorised operation
5. "Totmann" control
Let go off the operation button and the lift stops the movement

3.2 Data sheet

mobiles Hydraulikaggregat
mobile operating unit

Hebebühne fahrbereit
(nur ohne Fahrzeug)
Automatic-Lift movable
only without load

Optional:
Wird die Hebebühne verdrückt
ist ein Fundament mit einer
Betonqualität min. C20/25
zu gewährleisten.

A concrete quality min. C20/25
is necessary if the lift is
fasten on a foundation.

Jede befestigte und gerade Oberfläche
eignet sich als Aufstandsfläche.
Every solid and level surface
is suitable as location.

Tragfähigkeit: 3000 kg
capacity

Eigengewicht: ca. 480kg
own weight

Alle Maße in mm. All measure in millimeter
Mass- und Konstruktionsänderungen vorbehalten, subject to alterations!

flexible Hydraulikschlauch
3meter

flexible hydraulic hose
3meter

Wir weisen in unseren Plänen
auf die Mindestanforderung
des Fundamentes hin. Jedoch
der Zustand der örtlichen
Gegebenheiten (z.B. Untergrund)
beliegt nicht in unserer
Verantwortung. In besonderen
Fällen ist ein Architekt, Statiker
zu kontaktieren.

We point out the minimum requirement
of the foundation in our plans. The
condition of the local realities (for
example: ground under the foundation)
is not in our responsibility. If
necessary an architect must be
consulted.

TEL 07853/899-0 FAX 07853/8787
www.nussbaum-lifts.de
77694 KEHL-BODENSMETER

Sprinter Mobil 3000 025SPB00075	1715-S-EINBAU
07.07.08/M.G.	1715-S-EINBAU

3.3 Hydraulic diagram drawing

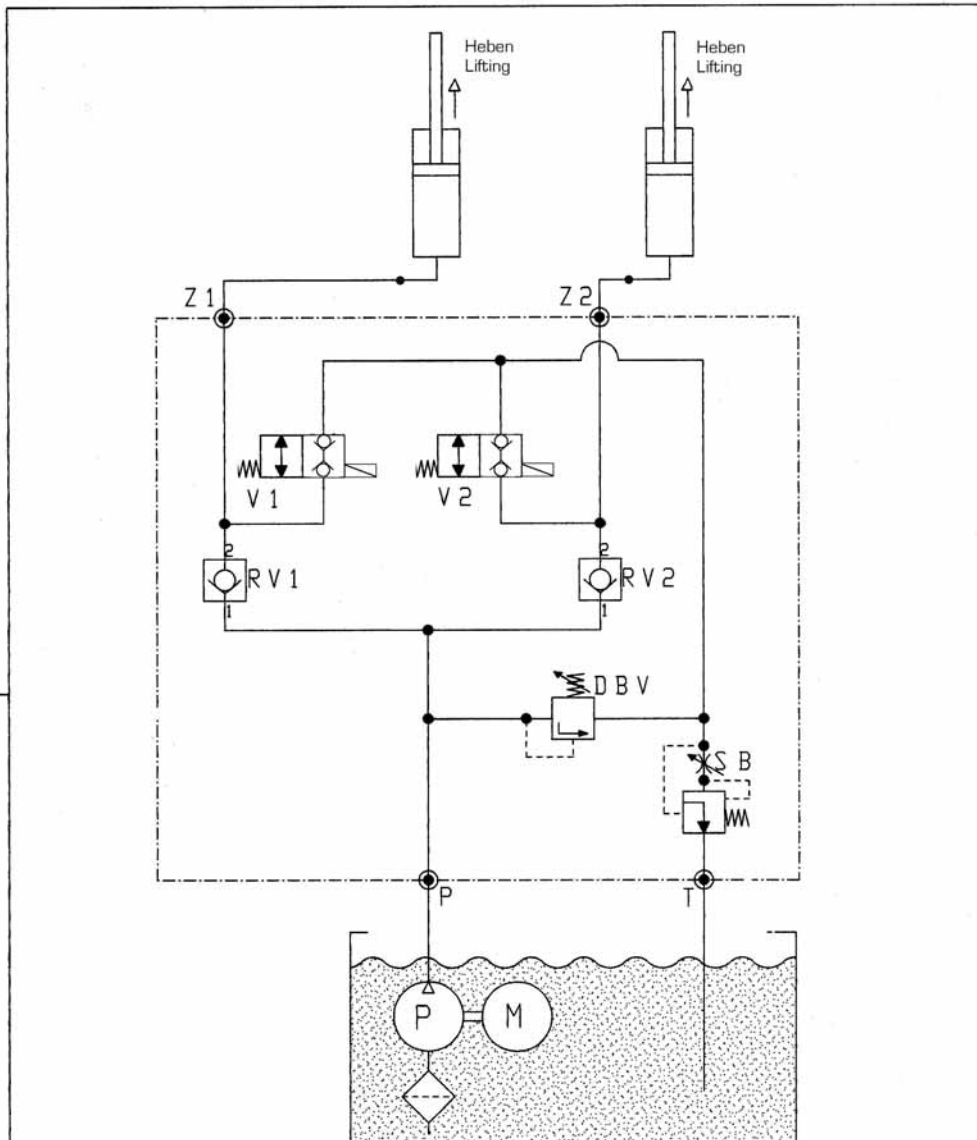

Maßstab		Stückzahl: X	
Werkstoff:			
Datum		Name	
Bearb. 06/04		M.G.	
Nussbaum			
Benennung		Blatt	
Hydraulikplan		Sprinter Mobil II 07-04	
Zeichnungsnummer		Ers. d.:	

0.1	oil filter	980012
0.2	sub oil motor 1,5 kW	991333
0.3	gear pump 4,3 cm ³	160554
0.4	hydraulic block	232HL01051
DBV	pressure control valve	232NSTL02082
RV1	holding valve	980480
RV2	holding valve	980480
V1	hand valve	158561
V2	hand valve	158561
SB	lowering valve	981063
1.0	Cylinder	025SPB22101
	hydraulic lines	025SPB44000 complete

3.4 Electric diagram

0	1	2	3	4	5	6	7	8	9
---	---	---	---	---	---	---	---	---	---



Nussbaum Hebeteknik
GmbH & Co. KG
Korker Straße 24
D-77694 Kohl Bodersweier
Tel.: +49(0)7853/899-0

SCHALTPLAN

OBJEKT : **Hydraulikplan valid**
ANLAGE : **Sprinter Mobil 3000**
KUNDE :
SCHALTPLANNR: Sprinter Standard II 09/04/001

3.) Sicherheitsprüfung und Schutzmaßnahmen
Der Schallschrank wurde unter Beachtung der angegebenen Regeln der Technik nach VDE0100/0113 sowie der Unfallverhütungsvorschrift VBG4 (elektrische Anlagen und Betriebsmittel) gefertigt bzw. errichtet und geprüft.
1. Spannungsprüfung und/oder Isolationsprüfung des Schallschrankes nach VDE0100/01.73.
2. Prüfung der Wirksamkeit der angeordneten Schutzmaßnahmen bei indirektem Berühren
3. Funktionsprüfung und Stückprüfung nach VDE960/11.87.
Alle Schutzmaßnahmen wurden getroffen:
1. Schutz bei indirektem Berühren nach VDE0100/01.73, par. 4.
2. Schutz bei direktem Berühren nach VDE0100/01.73, par. 5.

Erdung nach örtlichen Vorschriften
Vor Inbetriebnahme prüfen, ob Motorstrom mit Motorschutzrelais übereinstimmt. Alle Klemmstellen auf Ordnungsgemäße Verbindung und alle Kontaktschrauben auf festen Sitz prüfen.
Vor Inbetriebnahme Verdrehung und Steuerung auf richtige Funktion überprüfen. Keine Inbetriebnahme von unbefugter Seite vornehmen lassen. Änderungen vorbehalten

1.) Schaltpläne und Schaltunterlagen
Die Schaltpläne werden von uns nach besten Belieben angefertigt. Für bestmögliche Schaltpläne und Schaltunterlagen wird von uns keine Gewähr für die Richtigkeit dieser Unterlagen übernommen. Dies trifft insbesondere für Schaltungen zu, die von uns nach fremden Plänen angefertigt werden. Diese werden von uns nur nach den vom Auftraggeber überlassenen Unterlagen des Herstellers ausgeführt.

2.) Funktionsprüfung der Schaltanlagen
Schaltpläne sind keine Servicepläne. Bei der Prüfung des Schaltplanes im Werk können Fehler wie Fühler Thermistoren und Motoren nicht einbezogen werden. Auch bei sorgfältiger Prüfung lassen sich deshalb Funktions- und Schaltungsfehler nicht immer vermeiden. Sie können unter Umständen bei der Inbetriebnahme festgestellt werden.
Bei Inbetriebnahme ohne Mitzeichnung unseres Service wird deshalb keine Mängelhaftung übernommen. Wenn bei der Inbetriebnahme festgestellt wird, dass die Schaltung nicht nach den Service-Bauplänen ausgeführt ist, werden die Kosten für Nachbesserungen durch Dritte können wir nicht anerkennen.

Diese Pläne sind auf einem CAD-System erstellt worden.
Um die Pläne immer auf dem aktuellen Stand zu halten, bitten wir Änderungen nur durch uns vornehmen zu lassen.

3.) Sicherheitsprüfung und Schutzmaßnahmen
Der Schallschrank wurde unter Beachtung der angegebenen Regeln der Technik nach VDE0100/0113 sowie der Unfallverhütungsvorschrift VBG4 (elektrische Anlagen und Betriebsmittel) gefertigt bzw. errichtet und geprüft.
1. Spannungsprüfung und/oder Isolationsprüfung des Schallschrankes nach VDE0100/01.73.
2. Prüfung der Wirksamkeit der angeordneten Schutzmaßnahmen bei indirektem Berühren
3. Funktionsprüfung und Stückprüfung nach VDE960/11.87.
Alle Schutzmaßnahmen wurden getroffen:
1. Schutz bei indirektem Berühren nach VDE0100/01.73, par. 4.
2. Schutz bei direktem Berühren nach VDE0100/01.73, par. 5.

Diese Schaltpläne sind unser geistiges Eigentum.
Sie dürfen ohne unsere Genehmigung weder vervielfältigt noch Dritten weitergegeben werden!

1.) Datum: **23.09.2004**
2.) Bearb.: **BDE**
3.) Gepr.: **23.09.2004**

Nussbaum Hebeteknik GmbH & Co. KG
www.nussbaum.de
Korker Straße 24
D-77694 Kohl Bodersweier
Tel.: +49(0)7853/899-0 Fax: +49(0)7853/899-1

Änderung Datum Name Norm Urspr. Ers. f. Ers. d.

Nussbaum

Sprinter Standard II

Deckblatt

Standardaggregat

Bl. 1

5 Bl.

2

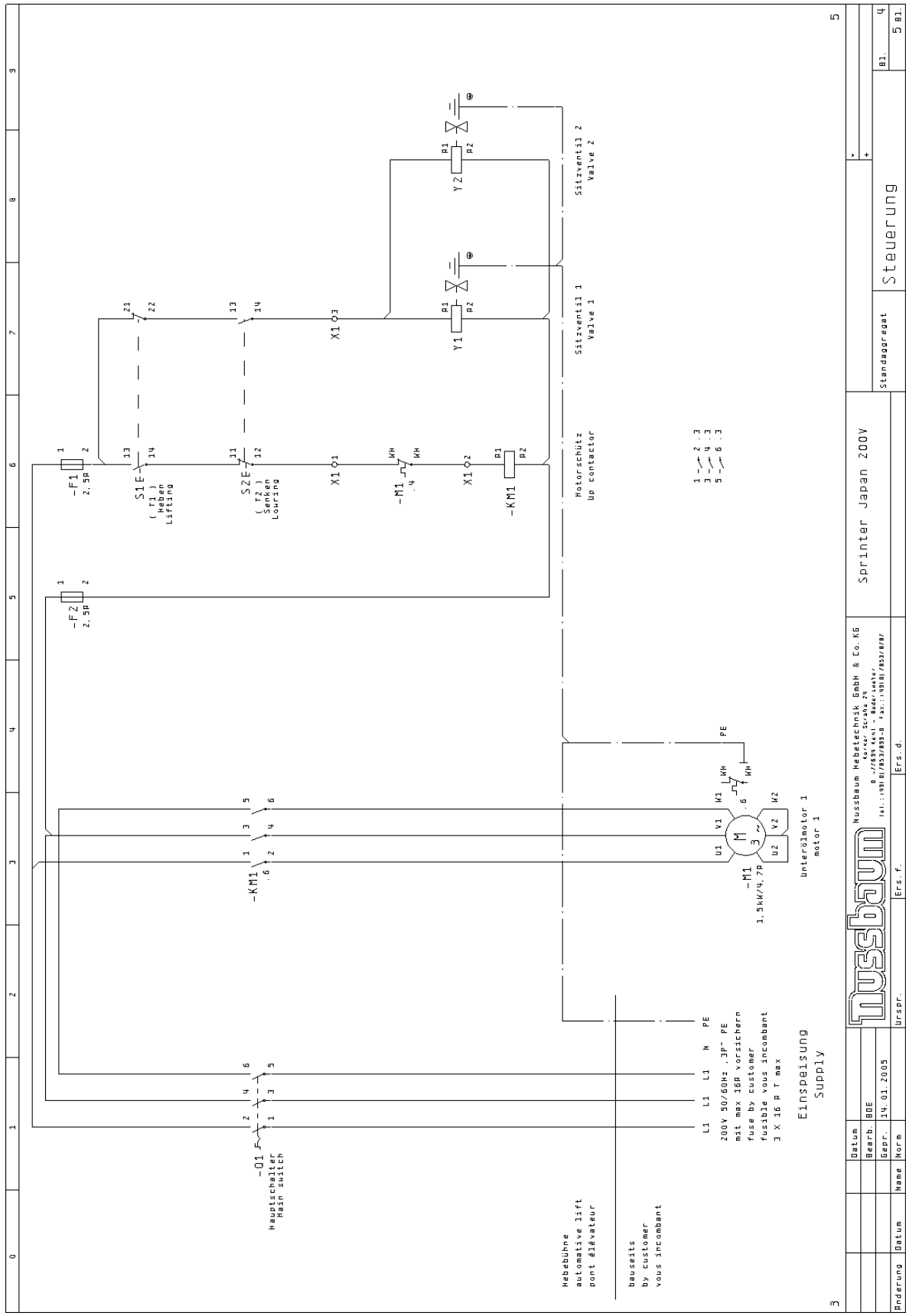

Datum		Sprinter Japan 200V		Steuerung	
Bearb. BDE		Nussbaum Hebe-technik GmbH & Co. KG		Standagreat	
Gepr. 14.01.2005		B. 72031 Kiel - Bismarkstr. 29		B1. 5 B1.	
Name Norm		urspr.		Ers. f. Ers. d.	

4. Safety regulations

If you use the automotive lift, the German following regulations are to be considered:
BGG945: Examine of automotive-lifts; BGR500 Using automotive-lifts; (VBG14).

Especially the following regulations are very important:

- Observe the detailed operating instruction.
- The laden weight of the lifted vehicle must not exceed 3000 kg for the automotive lift. The maximum load distribution is 3:2 in or against the drive-on direction.
- Observe the centre of gravity.
- The automotive lift must be in its lowest position, before the vehicle can be driving over the lift. Only then the vehicle can be lifted.
- The operation with the lift is only allowed on a solid and level surface.
- While working with the lift the operating instructions must be followed.
- Only trained personnel over the age of 18 years old are to operate this lift.
- No one is to stand within the working area (danger area) during lifting and lowering.
- No one is to be raised or lowed either directly or on the vehicle by the automotive lift.
- No one is to climb onto the automotive lift or onto an already raised vehicle.
- The automotive column lift must be checked by an expert after changes in the construction have been made.
- The main switch must be switched off and locked before work on the vehicle can commence. This is a safety precaution to ensure that the lift does not move during work.
- The main switch must be switched off and locked before any maintenance or repair work on the automotive lift itself can be carried out.
- During lifting or lowering the operator must observe the vehicle to ensure that the vehicle and the lift are functioning correctly.
- Installation of the standard vehicle lift in hazardous or dangerous locations such as washing bays is dangerous and is not allowed.
- Check the centre of gravity of the vehicle if heavy parts (egg the motor) are removed.
- If heavy parts must be removed (motor) the centre of gravity will change. Secure the vehicle before removing parts to avoid the possibility of the vehicle becoming insecure.
- At vehicles with low sub-ground clearance or with optional equipment (sport equipment) or sport-vehicles, it is to be tested previously whether damages can appear.

5. Operating instructions



The Safety Regulations must be observed during working with the automotive lift. Read the safety regulations in chapter 4 carefully before working with the lift!
If the vehicles are very short, the ramps must be taken off to guarantee that all wheels are free.
If the vehicles are very long, the carrying arms must be pulled out to elongate the rails with the help of the ramps.

5.1 Lifting the vehicle

- Remove the ramps, if the wheelbase is too short and the wheels are standing on the ramps.

Observe the centre of gravity.



If necessary fold out the extension ramps.

- Block the vehicle against rolling, put into gear.
- Check the dangerous places of the lift and be sure that there are no objects or people in the immediate area of the lift or on the lift.
- Switch on the control system; main switch on position "1" (see pic.1)
- Position the polymer supports under the pick-up points which are described by the vehicle manufacturer. Do not lay them on edge! The vehicle might fall down!
- Raise the lift. Press the button „Lifting“.
- Stop the lifting when the wheels are free to check the safe position of the vehicle on the polymer pads.
- Lift the vehicle on the working height. Press the button „Lifting“ .
- Observe the complete process.



Pic.1:

operating unit

Button "Lifting"
 Button "Lowering"
 Main switch

5.2 Lowering the vehicle

- Check all danger points of the lift and be sure that there are no objects or people in the working area (danger area) around the lift or on the lift.
- Lower the lift to the required working height or to its lowest (or fully collapsed) position. Press the button "lowering"
- Do not lower the lift in the lowest position if the vehicle is without wheels. Otherwise the lift cannot raise, due to its geometry, the vehicle under its own power.
- Observe the complete lowering process.
- If the lift is in its lowest position, remove the polymer supports.
- Drive the vehicle out of the lift if the lift is in the lowest position.

5.3 Change the installation place

- Lower the lift in the lowest position.
- Drive the vehicle from the lift.
- Raise the lift on a height of approx. 500mm.
- Use the mobile set. Put in the steering roller and the fixed roller.
- Lower the lift into the lowest position. Simultaneously, the base-plates lift themselves.
- Now the automotive-lift is movable.
- Remove the steering rod , if the lift is on the new place.
- Remove the mobile set.

6.Troubleshooting

If the lift does not work properly, the reason for this might be quite simple. Please check the lift for the potential reasons mentioned on the following pages. If the cause of trouble cannot be found, please call the technical service. We guess, to contact the customer service also with simple disturbances.

Problem: Motor does not start	
<i>Potential causes:</i>	<i>Repair failures</i>
<i>No power supply</i>	<i>Check the power supply cable</i>
<i>The main switch</i>	<i>Check the switch</i>
<i>Press button "▲" is defective</i>	<i>Check the lifting button</i>
<i>The Fuse is defective</i>	<i>Check it or exchange it</i>
<i>The motor is defective</i>	<i>Call the service partner</i>

Problem: Motor starts, lift does not lifting!	
<i>Potential causes:</i>	<i>Repair failures</i>
<i>The vehicle is too heavy</i>	<i>Unload the vehicle.</i>

<p><i>Level of the oil is too low</i></p> <p><i>gear pump does not work</i></p> <p><i>The pressure control valve is defective</i></p>	<p><i>Refill if necessary. Lower the lift in the lowest position. Remove the cover of the hydraulic unit. After the fill the oil level is between the upper and low marking of the oil level gauge (approx. 10 Litre)</i></p> <p><i>call your service partner</i></p> <p><i>Lower the lift in the lowest position. Remove the covering operating unit. Switch off the main switch. Remove the valve and clean it.</i></p>
---	---

<p>Problem: The lift does not lowered!</p> <p><i>Potential causes:</i></p> <p><i>The rail is sitting on a object. The lift stops through the mechanical resistance.</i></p> <p><i>The fuse is defective</i></p> <p><i>The way valve is defective</i></p>	<p><i>Repair failures</i></p> <p><i>Raise the lift with the button “▲” until the object can be removed.</i></p> <p><i>Check it or exchange it</i></p> <p><i>Carry out a emergency lowering. (read chapter emergency lowering) Remove the vehicle. Remove the valve and clean it. If necessary exchange it.</i></p>
---	--

6.1 Lowering on an obstacle

If the automotive-lift is lowering on a obstacle, the lift stops automatically. In this case press the button “lifting”, until the obstacle can be removed.

6.2 Emergency Lowering



***A emergency lowering is an intervention into the control of the lift and can be planned only by experienced expert.
The emergency lowering must be carried in this order. Otherwise a malfunction can lead it to damages or lead to danger for body and lives.***



- Check the dangerous places of the lift and be sure that there are no objects or people in the immediate area of the lift or on the lift.
- Switch off the main switch
- Loosen and remove the front cover of the operating unit.
- Press the black cap of the valves simultaneously down. The lowering process starts.
- Observe the complete process.
- Lower the lift in the lowest position.
- Remove the polymer supports.
- After the emergency lowering, the lift must shut down until the defective parts has been changed.

7. Inspection and Maintenance



Before conducting maintenance work, preparations must be made to ensure that during maintenance and repair work there is no risk to the safety of people working on or around the lift and also that there is no risk of damage to equipment being used on or around the lift.

To guarantee the utmost availability and to ensure that the lift remains functional, maintenance work contracts are organised between our clients and their local retailers.

A service must be performed at regular intervals of 3 months through the operator in accordance with following service manual. If the lift is in continuous operation or in a dirty environment, the maintenance rate must be increased.

During daily operation the lift must be closely observed to ensure that it is functioning correctly. In the case of malfunction or leakage the technical service must be informed.

7.1 Maintenance plan of the lift

- Before beginning any maintenance work isolate the power supply. Secure the main switch (lock it). Secure the danger area around the automotive lift and secure the lift against unintentional lowering.
- Clean the piston-rod using compressed air.
Grease the piston rods with a high capacity lipid (approx. 5 g of S2 DIN51503 KE2G available from the Renolit Company).
- Grease the lubricate nipples with a multipurpose lipid. (example: Auto Top 2000 LTD. Agip).
- Clean and lubricate the moving parts of the lift (hinge bolts, sliding pieces, sliding surfaces) grease with a multipurpose lipid (example: Auto Top 2000 LTD. Agip).
- Check the hydraulic tubes for leakage.
- Check the oil level. Fill the tank with a clean, high quality oil (32 cst) (e.g.g. HLP 32 LTD. OEST Company)
- The hydraulic oil has to be changed at least once a year. To change the oil, lower the lift into its lowest position. Empty all tanks and refill with clean oil, approx. 10 litres per hydraulic unit are needed.
Use an ATF-Suffix hydraulic-oil (OEST Company) if the ambient temperature is under 5 degrees centigrade. After filling, the hydraulic oil must be between the upper and lower markings of the oil level gauge.
Remove the old oil according to the appropriate regulations.
- Check all welded joints for cracks on the automotive-lift.
If any cracks are found on the lift cease use immediately. Switch-off and secure the main switch (lock) and call the service partner.
- Check all surfaces and repair if necessary.
- Damage to external surfaces, must be immediately repaired.
If these repairs are not made immediately, permanent damage to the powder-coated surface may result.
Repair and clean damaged areas with an abrasive paper (grain 120). After this is complete, use a suitable paint (observe the RAL Number).
- Check the zinc surface and repair it with a suitable tool. Use abrasive paper (grain 280).
White rust can result from moisture laying in certain areas for long periods of time. Poor aerating can also result in rust formation.
Rust may result from mechanical damage, wear, aggressive sediments (de-icing salt, liquids) or insufficient cleaning.
Repair and clean these areas with abrasive paper (grain 280).

After this is complete, use a suitable paint (observe the RAL Number).

- Check all the safety devices of the lift.
- Check the electric cable and channels for Damage.
- Check that all screws and bolts are correctly torque (turning moments, see the list Pic. 19)

Turning moment for screws

property class 8.8

	0,10*	0,15**	0,20***
M8	20	25	30
M10	40	50	60
M12	69	87	105
M16	170	220	260
M20	340	430	520
M24	590	740	890

property class 10.9

	0,10*	0,15**	0,20***
M8	30	37	44
M10	59	73	87
M12	100	125	151
M16	250	315	380
M20	490	615	740
M24	840	1050	1250

Drehmomenttabelle 8.8-10.9 E

- sliding friction 0,10 for very good surfaces, lubricated
- sliding friction 0,15 for good surfaces, lubricated oder dry
- sliding friction 0,20 surface black or phosphatized, dry

pic 4:

7.2 How often must the lift be cleaned?

A regular and appropriate maintenance practice will aid the preservation of the lift.

No guarantees can be given when damage (egg rust or fading colour) is the direct result of poor maintenance and cleaning practice.

Regular cleaning of all kinds of dirt is the best protection against wear and the formation of rust and will prolong the life of the lift

- Dirty deposits that can cause rust include:

- de-icing salt
- Sand, pebble stone, natural soil
- all types of industrial dust
- Water; also in connection with other environmental influences
- All types of aggressive deposits
- Constant humidity caused by insufficient ventilation

Obviously this is dependent on the type of work being done with the lift, the degree of cleanliness of the workshop and location of the lift. The degree and amount of dirt is dependent on the season, on the weather conditions and the ventilation of the workshop.

During poor conditions it may be necessary to clean the lift once week, but cleaning once a month will suffice.

Clean the lift and the floor with a non-aggressive and non-abrasive detergent. Use a gentle detergent to clean the parts. Use an standard washing-up liquid and lukewarm water.

- Do not use steam jet cleaners.
- Remove all dirt carefully with a sponge or if necessary with a brush.
- Ensure that no washing-up liquid is left on the lift after cleaning.

- Do not use aggressive means for cleaning the workshop floor and the automotive lift.
- A permanent contact with any kind of liquid is not allowed. Do not use high pressure devices for cleaning the lift.

8. Security check

The security check is necessary to guarantee the safety of the lifting during use. It has to be performed in the following cases:

1. Before the initial operation, after the first installation
Use the form "First security check before initiation"
2. In regular intervals after the initial operation, at least annually.
Use the form "Regular security check at least annually"
3. Every time the construction of that particular lift has been changed.
Use the form "Extraordinary security check"



The first and the regular security check must be performed by a competent person. It is recommended to service the lift at this occasion.



After the construction of the lift has been changed (changing the lifting height or capacity for example) and after serious maintenance works (welding on carrying parts) an extraordinary security check must be performed by an expert.

This manual contains form with a schedule for the security checks. Please use the adequate form for the security checks. The form should remain in this manual after they have been filled out. In the following there is a short description about special safety devices.

9. Installation

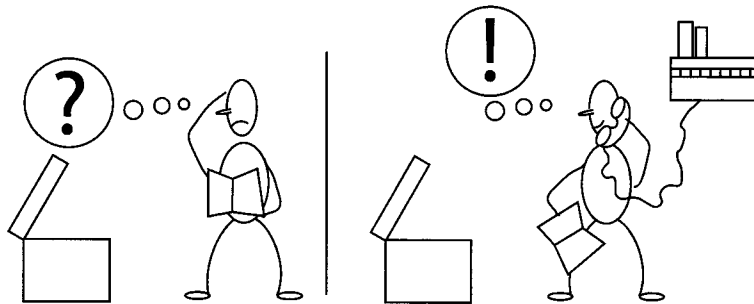

9.1 Regulations

- It is possible to fasten the Lift on a even floor with dowels. (See the dowel pages)
- The installation of the lift is performed by trained technicians of the manufacturer or one of its distribution partners. If the operator can provide trained mechanics, he or she can install the lift by him or herself. The installation has to be done according to this regulation.
- Bore holes in the foundations so that base plates and be bolted down. Clean the holes with compressed air. Put masonry bolts in and secure. The lift-manufacturer recommended Liebig, Fischer or Hilti safety masonry bolts or equally good bolts from another manufacturer (with licence). Be sure to observe their regulations (bore hole, torque...). Before bolting, check that the concrete- floor is of quality min.C20/25, thickness min.160mm normal armouring. If the entire floor is concrete (there is no surface covering), bolts must be

selected according to a floor without a surface covering. If the ground is covered with floor tiles or some other form of surface covering, the bolts must be selected according to the floor with floor covering.

- Installing the standard-automotive lift in a hazardous location or a washing bay is not allowed.
- Before installation a sufficient foundation must be constructed. If the foundation is already constructed then proof that the foundation conforms to the standard is required. A level foundation for the installation is required. The foundations must be based in a frost resistance depth, both outdoors and indoors in a position where the installer believes there is no chance of frost.
- An electrical supply 3~/N+PE, 400 V, 50Hz must be provided. The supply line must be protected with a time-lag fuse T16A (VDE0100 German regulation). The minimum diameter amounts to 2.5 mm².
- All cable ducts must be equipped with protective coverings to prevent accidents.

9.2 Initiation

The Sprinter Mobil was checked by Nußbaum Company. Before the first initiation the test must not additional take through by an expert.

9.3 Change the installation place

The automotive–lift is a flexible lifting device. It is possible to change the position of the lift only without load.

Every solid and even surface is suitable as location. The location has to admit a load capacity of 3000kg and also own weight of about 480kg.

The Sprinter Express II is quickly operational. The operating unit is moveable, too.

By changing the installation place, you must meet the preconditions according to the recommendation.



Use new dowels, the old dowels cannot be used.

Choice of the dowel length without floor pavement or tile surface

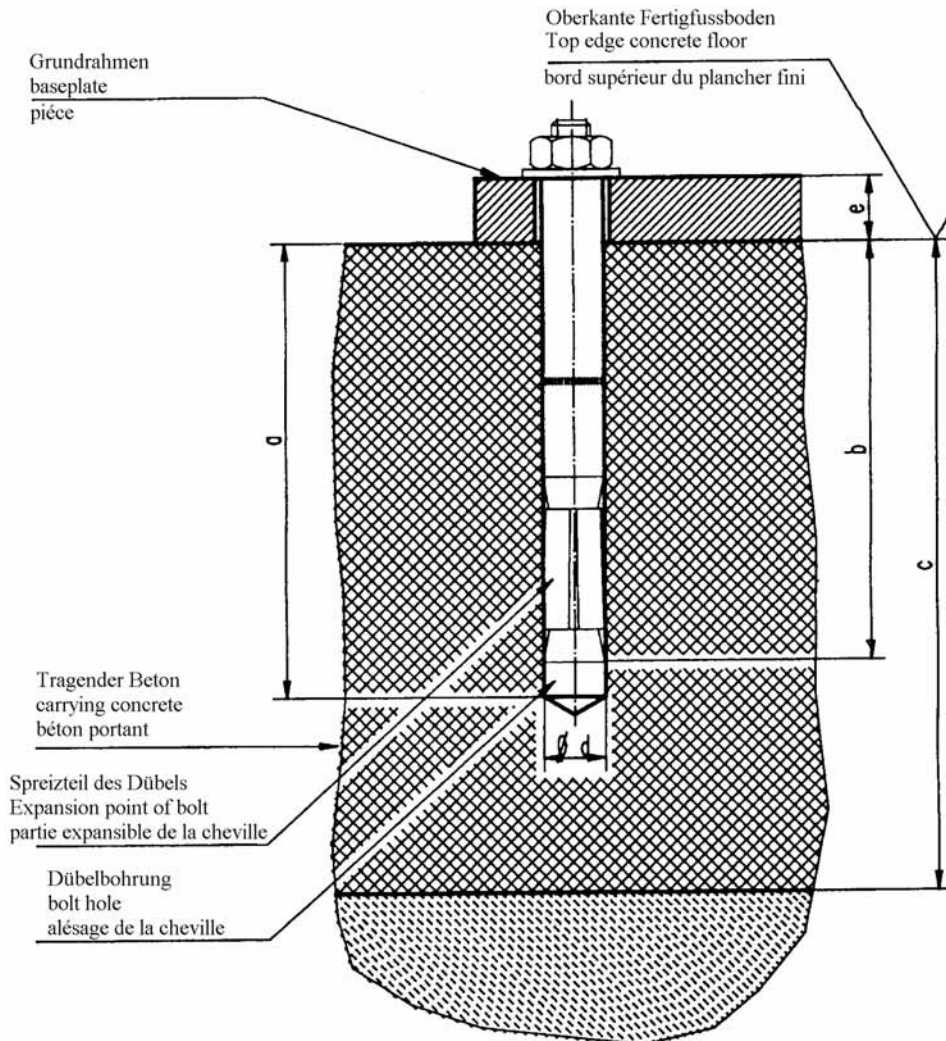

Table to pic.

Liebig-dowels

Dowel type		BM10-/70/40
Drilling depth	a	85
Min. anchorage depth	b	70
Thickness of concrete	c	min.140
Diameter of bore	d	15
Thickness of the lift-pieces	e	0-40
Number of dowels		8
Starting torque		40

(*) minimum thickness of concrete by using the mentioned dowels. Otherwise, observe the regulation of the foundation plan.

You can use equivalent dowels from another dowel manufacturer (with license) but observe their regulation.

Choice of the dowel length with floor pavement or tile surface

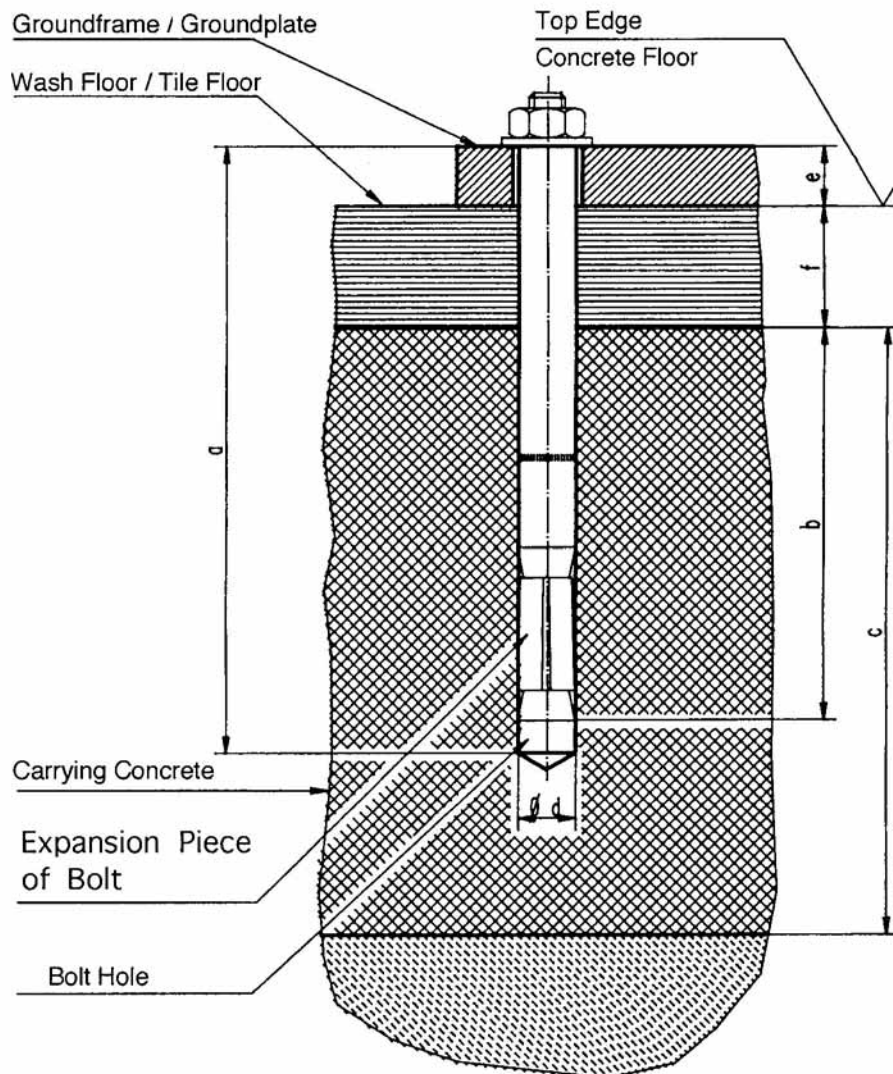

Table to pic.

Liebig-dowels

Dowel type	BM10-15/70/65	BM10-15/0/100	BM10-15/70/140
Drilling depth (mm)	a 85	85	85
Min. anchorage depth (mm)	b 70	70	70
Thickness of concrete (mm)	c min.140(*)	min.140(*)	min.140(*)
Diameter of bore (mm)	d 15	15	15
Thickness of the lift-pieces (mm)	e 40-65	65-100	100-140
Number of dowels	x	x	x
Starting torque (Nm)	40 Nm	40Nm	40Nm

(*) minimum thickness of concrete by using the mentioned dowels. Otherwise, observe the regulation of the foundation plan.

You can use equivalent dowels from another dowel manufacturer (with license) but observe their regulation.

First security check before installation

Serial-number: _____



Complete and leave in this manual

Kind of check	all right	defect missing	verification	remark
Type plate.....	<input type="checkbox"/>	<input type="checkbox"/>	<input type="checkbox"/>
Short operating instruction.....	<input type="checkbox"/>	<input type="checkbox"/>	<input type="checkbox"/>
Warning designation.....	<input type="checkbox"/>	<input type="checkbox"/>	<input type="checkbox"/>
Sticker "max. capacity".....	<input type="checkbox"/>	<input type="checkbox"/>	<input type="checkbox"/>
Sticker "Centre of gravity".....	<input type="checkbox"/>	<input type="checkbox"/>	<input type="checkbox"/>
Function lifting/lowering.....	<input type="checkbox"/>	<input type="checkbox"/>	<input type="checkbox"/>
Detailed operating instruction.....	<input type="checkbox"/>	<input type="checkbox"/>	<input type="checkbox"/>
Condition concrete.....	<input type="checkbox"/>	<input type="checkbox"/>	<input type="checkbox"/>
Safety device of hinge bolt.....	<input type="checkbox"/>	<input type="checkbox"/>	<input type="checkbox"/>
Condition automotive lift.....	<input type="checkbox"/>	<input type="checkbox"/>	<input type="checkbox"/>
Condition colour.....	<input type="checkbox"/>	<input type="checkbox"/>	<input type="checkbox"/>
Construction (deformation, cracking)	<input type="checkbox"/>	<input type="checkbox"/>	<input type="checkbox"/>
Torque of the dowels (bolts).....	<input type="checkbox"/>	<input type="checkbox"/>	<input type="checkbox"/>
Torque moments of the screws	<input type="checkbox"/>	<input type="checkbox"/>	<input type="checkbox"/>
Condition operating unit.....	<input type="checkbox"/>	<input type="checkbox"/>	<input type="checkbox"/>
Condition surface piston rod	<input type="checkbox"/>	<input type="checkbox"/>	<input type="checkbox"/>
Condition coverings.....	<input type="checkbox"/>	<input type="checkbox"/>	<input type="checkbox"/>
Condition electrical wires	<input type="checkbox"/>	<input type="checkbox"/>	<input type="checkbox"/>
Level of hydraulic oil	<input type="checkbox"/>	<input type="checkbox"/>	<input type="checkbox"/>
Closeness of the hydraulic system.....	<input type="checkbox"/>	<input type="checkbox"/>	<input type="checkbox"/>
Condition hydraulic hoses.....	<input type="checkbox"/>	<input type="checkbox"/>	<input type="checkbox"/>
Function test with vehicle.....	<input type="checkbox"/>	<input type="checkbox"/>	<input type="checkbox"/>
Function safety devices.....	<input type="checkbox"/>	<input type="checkbox"/>	<input type="checkbox"/>
Condition welding.....	<input type="checkbox"/>	<input type="checkbox"/>	<input type="checkbox"/>
Condition, function mobile set.....	<input type="checkbox"/>	<input type="checkbox"/>	<input type="checkbox"/>

(mark here applicable, in case of verification mark in addition to the first mark!)

Security check carried out:.....

Carried out the company:.....

Name, address of the competent:.....

Result of the Check:

- Initiation not permitted, verification necessary
- Initiation possible, repair failures until.....
- No failings, Initiation possible

.....
signature of the expert

.....
signature of the operator

If failures must be repaired:

Failures repaired at:signature of the operator

(Use another form for verification!)

Regular security check and Maintenance

Serial-number: _____



Filling out and leave in this manual

kind of check	all right	defect missing	verification	remark
Type plate.....	<input type="checkbox"/>	<input type="checkbox"/>	<input type="checkbox"/>
Short operating instruction.....	<input type="checkbox"/>	<input type="checkbox"/>	<input type="checkbox"/>
Warning designation.....	<input type="checkbox"/>	<input type="checkbox"/>	<input type="checkbox"/>
Sticker "max. capacity".....	<input type="checkbox"/>	<input type="checkbox"/>	<input type="checkbox"/>
Sticker "Centre of gravity".....	<input type="checkbox"/>	<input type="checkbox"/>	<input type="checkbox"/>
Function lifting/lowering.....	<input type="checkbox"/>	<input type="checkbox"/>	<input type="checkbox"/>
Detailed operating instruction.....	<input type="checkbox"/>	<input type="checkbox"/>	<input type="checkbox"/>
Condition concrete.....	<input type="checkbox"/>	<input type="checkbox"/>	<input type="checkbox"/>
Safety device of hinge bolt.....	<input type="checkbox"/>	<input type="checkbox"/>	<input type="checkbox"/>
Condition automotive lift.....	<input type="checkbox"/>	<input type="checkbox"/>	<input type="checkbox"/>
Condition colour.....	<input type="checkbox"/>	<input type="checkbox"/>	<input type="checkbox"/>
Construction (deformation, cracking)	<input type="checkbox"/>	<input type="checkbox"/>	<input type="checkbox"/>
Torque of the dowels (bolts).....	<input type="checkbox"/>	<input type="checkbox"/>	<input type="checkbox"/>
Torque moments of the screws	<input type="checkbox"/>	<input type="checkbox"/>	<input type="checkbox"/>
Condition operating unit.....	<input type="checkbox"/>	<input type="checkbox"/>	<input type="checkbox"/>
Condition surface piston rod	<input type="checkbox"/>	<input type="checkbox"/>	<input type="checkbox"/>
Condition coverings.....	<input type="checkbox"/>	<input type="checkbox"/>	<input type="checkbox"/>
Condition electrical wires	<input type="checkbox"/>	<input type="checkbox"/>	<input type="checkbox"/>
Level of hydraulic oil	<input type="checkbox"/>	<input type="checkbox"/>	<input type="checkbox"/>
Closeness of the hydraulic system.....	<input type="checkbox"/>	<input type="checkbox"/>	<input type="checkbox"/>
Condition hydraulic hoses.....	<input type="checkbox"/>	<input type="checkbox"/>	<input type="checkbox"/>
Function test with vehicle.....	<input type="checkbox"/>	<input type="checkbox"/>	<input type="checkbox"/>
Function safety devices.....	<input type="checkbox"/>	<input type="checkbox"/>	<input type="checkbox"/>
Condition welding.....	<input type="checkbox"/>	<input type="checkbox"/>	<input type="checkbox"/>
Condition, function mobile set.....	<input type="checkbox"/>	<input type="checkbox"/>	<input type="checkbox"/>

(mark here applicable, in case of verification mark in addition to the first mark!)

Security check carried out:.....

Carried out the company:.....

Name, address of the competent:.....

Result of the Check:

- Initiation not permitted, verification necessary
- Initiation possible, repair failures until.....
- No failings, Initiation possible

.....
signature of the expert

.....
signature of the operator

If failures must be repaired:

Failures repaired at:signature of the operator

(Use another form for verification!)

Regular security check and Maintenance

Serial-number: _____

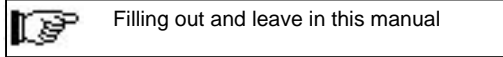

kind of check	all right	defect missing	verification	remark
Type plate.....	<input type="checkbox"/>	<input type="checkbox"/>	<input type="checkbox"/>
Short operating instruction.....	<input type="checkbox"/>	<input type="checkbox"/>	<input type="checkbox"/>
Warning designation.....	<input type="checkbox"/>	<input type="checkbox"/>	<input type="checkbox"/>
Sticker "max. capacity".....	<input type="checkbox"/>	<input type="checkbox"/>	<input type="checkbox"/>
Sticker "Centre of gravity".....	<input type="checkbox"/>	<input type="checkbox"/>	<input type="checkbox"/>
Function lifting/lowering.....	<input type="checkbox"/>	<input type="checkbox"/>	<input type="checkbox"/>
Detailed operating instruction.....	<input type="checkbox"/>	<input type="checkbox"/>	<input type="checkbox"/>
Condition concrete.....	<input type="checkbox"/>	<input type="checkbox"/>	<input type="checkbox"/>
Safety device of hinge bolt.....	<input type="checkbox"/>	<input type="checkbox"/>	<input type="checkbox"/>
Condition automotive lift.....	<input type="checkbox"/>	<input type="checkbox"/>	<input type="checkbox"/>
Condition colour.....	<input type="checkbox"/>	<input type="checkbox"/>	<input type="checkbox"/>
Construction (deformation, cracking).....	<input type="checkbox"/>	<input type="checkbox"/>	<input type="checkbox"/>
Torque of the dowels (bolts).....	<input type="checkbox"/>	<input type="checkbox"/>	<input type="checkbox"/>
Torque moments of the screws.....	<input type="checkbox"/>	<input type="checkbox"/>	<input type="checkbox"/>
Condition operating unit.....	<input type="checkbox"/>	<input type="checkbox"/>	<input type="checkbox"/>
Condition surface piston rod.....	<input type="checkbox"/>	<input type="checkbox"/>	<input type="checkbox"/>
Condition coverings.....	<input type="checkbox"/>	<input type="checkbox"/>	<input type="checkbox"/>
Condition electrical wires.....	<input type="checkbox"/>	<input type="checkbox"/>	<input type="checkbox"/>
Level of hydraulic oil.....	<input type="checkbox"/>	<input type="checkbox"/>	<input type="checkbox"/>
Closeness of the hydraulic system.....	<input type="checkbox"/>	<input type="checkbox"/>	<input type="checkbox"/>
Condition hydraulic hoses.....	<input type="checkbox"/>	<input type="checkbox"/>	<input type="checkbox"/>
Function test with vehicle.....	<input type="checkbox"/>	<input type="checkbox"/>	<input type="checkbox"/>
Function safety devices.....	<input type="checkbox"/>	<input type="checkbox"/>	<input type="checkbox"/>
Condition welding.....	<input type="checkbox"/>	<input type="checkbox"/>	<input type="checkbox"/>
Condition, function mobile set.....	<input type="checkbox"/>	<input type="checkbox"/>	<input type="checkbox"/>

(mark here applicable, in case of verification mark in addition to the first mark!)

Security check carried out:.....

Carried out the company:.....

Name, address of the competent:.....

Result of the Check:

- Initiation not permitted, verification necessary
- Initiation possible, repair failures until.....
- No failings, Initiation possible

.....
signature of the expert

.....
signature of the operator

If failures must be repaired:

Failures repaired at:signature of the operator

(Use another form for verification!)

Regular security check and Maintenance

Serial-number: _____

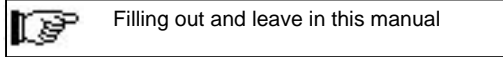

kind of check	all right	defect missing	verifi- fication	ver- remark
Type plate.....	<input type="checkbox"/>	<input type="checkbox"/>	<input type="checkbox"/>
Short operating instruction.....	<input type="checkbox"/>	<input type="checkbox"/>	<input type="checkbox"/>
Warning designation.....	<input type="checkbox"/>	<input type="checkbox"/>	<input type="checkbox"/>
Sticker "max. capacity".....	<input type="checkbox"/>	<input type="checkbox"/>	<input type="checkbox"/>
Sticker "Centre of gravity".....	<input type="checkbox"/>	<input type="checkbox"/>	<input type="checkbox"/>
Function lifting/lowering.....	<input type="checkbox"/>	<input type="checkbox"/>	<input type="checkbox"/>
Detailed operating instruction.....	<input type="checkbox"/>	<input type="checkbox"/>	<input type="checkbox"/>
Condition concrete.....	<input type="checkbox"/>	<input type="checkbox"/>	<input type="checkbox"/>
Safety device of hinge bolt.....	<input type="checkbox"/>	<input type="checkbox"/>	<input type="checkbox"/>
Condition automotive lift.....	<input type="checkbox"/>	<input type="checkbox"/>	<input type="checkbox"/>
Condition colour.....	<input type="checkbox"/>	<input type="checkbox"/>	<input type="checkbox"/>
Construction (deformation, cracking).....	<input type="checkbox"/>	<input type="checkbox"/>	<input type="checkbox"/>
Torque of the dowels (bolts).....	<input type="checkbox"/>	<input type="checkbox"/>	<input type="checkbox"/>
Torque moments of the screws.....	<input type="checkbox"/>	<input type="checkbox"/>	<input type="checkbox"/>
Condition operating unit.....	<input type="checkbox"/>	<input type="checkbox"/>	<input type="checkbox"/>
Condition surface piston rod.....	<input type="checkbox"/>	<input type="checkbox"/>	<input type="checkbox"/>
Condition coverings.....	<input type="checkbox"/>	<input type="checkbox"/>	<input type="checkbox"/>
Condition electrical wires.....	<input type="checkbox"/>	<input type="checkbox"/>	<input type="checkbox"/>
Level of hydraulic oil.....	<input type="checkbox"/>	<input type="checkbox"/>	<input type="checkbox"/>
Closeness of the hydraulic system.....	<input type="checkbox"/>	<input type="checkbox"/>	<input type="checkbox"/>
Condition hydraulic hoses.....	<input type="checkbox"/>	<input type="checkbox"/>	<input type="checkbox"/>
Function test with vehicle.....	<input type="checkbox"/>	<input type="checkbox"/>	<input type="checkbox"/>
Function safety devices.....	<input type="checkbox"/>	<input type="checkbox"/>	<input type="checkbox"/>
Condition welding.....	<input type="checkbox"/>	<input type="checkbox"/>	<input type="checkbox"/>
Condition, function mobile set.....	<input type="checkbox"/>	<input type="checkbox"/>	<input type="checkbox"/>

(mark here applicable, in case of verification mark in addition to the first mark!)

Security check carried out:.....

Carried out the company:.....

Name, address of the competent:.....

Result of the Check:

- Initiation not permitted, verification necessary
- Initiation possible, repair failures until.....
- No failings, Initiation possible

.....
signature of the expert

.....
signature of the operator

If failures must be repaired:

Failures repaired at:signature of the operator

(Use another form for verification!)

Regular security check and Maintenance

Serial-number: _____

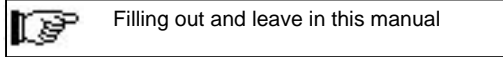

kind of check	all right	defect missing	verification	veri-remark
Type plate.....	<input type="checkbox"/>	<input type="checkbox"/>	<input type="checkbox"/>
Short operating instruction.....	<input type="checkbox"/>	<input type="checkbox"/>	<input type="checkbox"/>
Warning designation.....	<input type="checkbox"/>	<input type="checkbox"/>	<input type="checkbox"/>
Sticker "max. capacity".....	<input type="checkbox"/>	<input type="checkbox"/>	<input type="checkbox"/>
Sticker "Centre of gravity".....	<input type="checkbox"/>	<input type="checkbox"/>	<input type="checkbox"/>
Function lifting/lowering.....	<input type="checkbox"/>	<input type="checkbox"/>	<input type="checkbox"/>
Detailed operating instruction.....	<input type="checkbox"/>	<input type="checkbox"/>	<input type="checkbox"/>
Condition concrete.....	<input type="checkbox"/>	<input type="checkbox"/>	<input type="checkbox"/>
Safety device of hinge bolt.....	<input type="checkbox"/>	<input type="checkbox"/>	<input type="checkbox"/>
Condition automotive lift.....	<input type="checkbox"/>	<input type="checkbox"/>	<input type="checkbox"/>
Condition colour.....	<input type="checkbox"/>	<input type="checkbox"/>	<input type="checkbox"/>
Construction (deformation, cracking).....	<input type="checkbox"/>	<input type="checkbox"/>	<input type="checkbox"/>
Torque of the dowels (bolts).....	<input type="checkbox"/>	<input type="checkbox"/>	<input type="checkbox"/>
Torque moments of the screws.....	<input type="checkbox"/>	<input type="checkbox"/>	<input type="checkbox"/>
Condition operating unit.....	<input type="checkbox"/>	<input type="checkbox"/>	<input type="checkbox"/>
Condition surface piston rod.....	<input type="checkbox"/>	<input type="checkbox"/>	<input type="checkbox"/>
Condition coverings.....	<input type="checkbox"/>	<input type="checkbox"/>	<input type="checkbox"/>
Condition electrical wires.....	<input type="checkbox"/>	<input type="checkbox"/>	<input type="checkbox"/>
Level of hydraulic oil.....	<input type="checkbox"/>	<input type="checkbox"/>	<input type="checkbox"/>
Closeness of the hydraulic system.....	<input type="checkbox"/>	<input type="checkbox"/>	<input type="checkbox"/>
Condition hydraulic hoses.....	<input type="checkbox"/>	<input type="checkbox"/>	<input type="checkbox"/>
Function test with vehicle.....	<input type="checkbox"/>	<input type="checkbox"/>	<input type="checkbox"/>
Function safety devices.....	<input type="checkbox"/>	<input type="checkbox"/>	<input type="checkbox"/>
Condition welding.....	<input type="checkbox"/>	<input type="checkbox"/>	<input type="checkbox"/>
Condition, function mobile set.....	<input type="checkbox"/>	<input type="checkbox"/>	<input type="checkbox"/>

(mark here applicable, in case of verification mark in addition to the first mark!)

Security check carried out:.....

Carried out the company:.....

Name, address of the competent:.....

Result of the Check:

- Initiation not permitted, verification necessary
- Initiation possible, repair failures until.....
- No failings, Initiation possible

.....
signature of the expert

.....
signature of the operator

If failures must be repaired:

Failures repaired at:signature of the operator

(Use another form for verification!)

Regular security check and Maintenance

Serial-number: _____

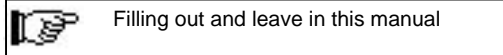

kind of check	all right	defect missing	verifi- cation	veri- remark
Type plate.....	<input type="checkbox"/>	<input type="checkbox"/>	<input type="checkbox"/>
Short operating instruction.....	<input type="checkbox"/>	<input type="checkbox"/>	<input type="checkbox"/>
Warning designation.....	<input type="checkbox"/>	<input type="checkbox"/>	<input type="checkbox"/>
Sticker "max. capacity".....	<input type="checkbox"/>	<input type="checkbox"/>	<input type="checkbox"/>
Sticker "Centre of gravity".....	<input type="checkbox"/>	<input type="checkbox"/>	<input type="checkbox"/>
Function lifting/lowering.....	<input type="checkbox"/>	<input type="checkbox"/>	<input type="checkbox"/>
Detailed operating instruction.....	<input type="checkbox"/>	<input type="checkbox"/>	<input type="checkbox"/>
Condition concrete.....	<input type="checkbox"/>	<input type="checkbox"/>	<input type="checkbox"/>
Safety device of hinge bolt.....	<input type="checkbox"/>	<input type="checkbox"/>	<input type="checkbox"/>
Condition automotive lift.....	<input type="checkbox"/>	<input type="checkbox"/>	<input type="checkbox"/>
Condition colour.....	<input type="checkbox"/>	<input type="checkbox"/>	<input type="checkbox"/>
Construction (deformation, cracking).....	<input type="checkbox"/>	<input type="checkbox"/>	<input type="checkbox"/>
Torque of the dowels (bolts).....	<input type="checkbox"/>	<input type="checkbox"/>	<input type="checkbox"/>
Torque moments of the screws.....	<input type="checkbox"/>	<input type="checkbox"/>	<input type="checkbox"/>
Condition operating unit.....	<input type="checkbox"/>	<input type="checkbox"/>	<input type="checkbox"/>
Condition surface piston rod.....	<input type="checkbox"/>	<input type="checkbox"/>	<input type="checkbox"/>
Condition coverings.....	<input type="checkbox"/>	<input type="checkbox"/>	<input type="checkbox"/>
Condition electrical wires.....	<input type="checkbox"/>	<input type="checkbox"/>	<input type="checkbox"/>
Level of hydraulic oil.....	<input type="checkbox"/>	<input type="checkbox"/>	<input type="checkbox"/>
Closeness of the hydraulic system.....	<input type="checkbox"/>	<input type="checkbox"/>	<input type="checkbox"/>
Condition hydraulic hoses.....	<input type="checkbox"/>	<input type="checkbox"/>	<input type="checkbox"/>
Function test with vehicle.....	<input type="checkbox"/>	<input type="checkbox"/>	<input type="checkbox"/>
Function safety devices.....	<input type="checkbox"/>	<input type="checkbox"/>	<input type="checkbox"/>
Condition welding.....	<input type="checkbox"/>	<input type="checkbox"/>	<input type="checkbox"/>
Condition, function mobile set.....	<input type="checkbox"/>	<input type="checkbox"/>	<input type="checkbox"/>

(mark here applicable, in case of verification mark in addition to the first mark!)

Security check carried out:.....

Carried out the company:.....

Name, address of the competent:.....

Result of the Check:

- Initiation not permitted, verification necessary
- Initiation possible, repair failures until.....
- No failings, Initiation possible

.....
signature of the expert

.....
signature of the operator

If failures must be repaired:

Failures repaired at:signature of the operator

(Use another form for verification!)

Regular security check and Maintenance

Serial-number: _____

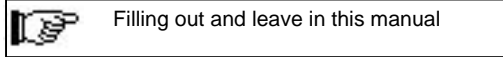

kind of check	all right	defect missing	verifi- fication	veri- remark
Type plate.....	<input type="checkbox"/>	<input type="checkbox"/>	<input type="checkbox"/>
Short operating instruction.....	<input type="checkbox"/>	<input type="checkbox"/>	<input type="checkbox"/>
Warning designation.....	<input type="checkbox"/>	<input type="checkbox"/>	<input type="checkbox"/>
Sticker "max. capacity".....	<input type="checkbox"/>	<input type="checkbox"/>	<input type="checkbox"/>
Sticker "Centre of gravity".....	<input type="checkbox"/>	<input type="checkbox"/>	<input type="checkbox"/>
Function lifting/lowering.....	<input type="checkbox"/>	<input type="checkbox"/>	<input type="checkbox"/>
Detailed operating instruction.....	<input type="checkbox"/>	<input type="checkbox"/>	<input type="checkbox"/>
Condition concrete.....	<input type="checkbox"/>	<input type="checkbox"/>	<input type="checkbox"/>
Safety device of hinge bolt.....	<input type="checkbox"/>	<input type="checkbox"/>	<input type="checkbox"/>
Condition automotive lift.....	<input type="checkbox"/>	<input type="checkbox"/>	<input type="checkbox"/>
Condition colour.....	<input type="checkbox"/>	<input type="checkbox"/>	<input type="checkbox"/>
Construction (deformation, cracking).....	<input type="checkbox"/>	<input type="checkbox"/>	<input type="checkbox"/>
Torque of the dowels (bolts).....	<input type="checkbox"/>	<input type="checkbox"/>	<input type="checkbox"/>
Torque moments of the screws.....	<input type="checkbox"/>	<input type="checkbox"/>	<input type="checkbox"/>
Condition operating unit.....	<input type="checkbox"/>	<input type="checkbox"/>	<input type="checkbox"/>
Condition surface piston rod.....	<input type="checkbox"/>	<input type="checkbox"/>	<input type="checkbox"/>
Condition coverings.....	<input type="checkbox"/>	<input type="checkbox"/>	<input type="checkbox"/>
Condition electrical wires.....	<input type="checkbox"/>	<input type="checkbox"/>	<input type="checkbox"/>
Level of hydraulic oil.....	<input type="checkbox"/>	<input type="checkbox"/>	<input type="checkbox"/>
Closeness of the hydraulic system.....	<input type="checkbox"/>	<input type="checkbox"/>	<input type="checkbox"/>
Condition hydraulic hoses.....	<input type="checkbox"/>	<input type="checkbox"/>	<input type="checkbox"/>
Function test with vehicle.....	<input type="checkbox"/>	<input type="checkbox"/>	<input type="checkbox"/>
Function safety devices.....	<input type="checkbox"/>	<input type="checkbox"/>	<input type="checkbox"/>
Condition welding.....	<input type="checkbox"/>	<input type="checkbox"/>	<input type="checkbox"/>
Condition, function mobile set.....	<input type="checkbox"/>	<input type="checkbox"/>	<input type="checkbox"/>

(mark here applicable, in case of verification mark in addition to the first mark!)

Security check carried out:.....

Carried out the company:.....

Name, address of the competent:.....

Result of the Check:

- Initiation not permitted, verification necessary
- Initiation possible, repair failures until.....
- No failings, Initiation possible

.....
signature of the expert

.....
signature of the operator

If failures must be repaired:

Failures repaired at:signature of the operator

(Use another form for verification!)

Regular security check and Maintenance

Serial-number: _____



Filling out and leave in this manual

kind of check	all right	defect missing	verifi- fication	ver- remark
Type plate.....	<input type="checkbox"/>	<input type="checkbox"/>	<input type="checkbox"/>
Short operating instruction.....	<input type="checkbox"/>	<input type="checkbox"/>	<input type="checkbox"/>
Warning designation.....	<input type="checkbox"/>	<input type="checkbox"/>	<input type="checkbox"/>
Sticker "max. capacity".....	<input type="checkbox"/>	<input type="checkbox"/>	<input type="checkbox"/>
Sticker "Centre of gravity".....	<input type="checkbox"/>	<input type="checkbox"/>	<input type="checkbox"/>
Function lifting/lowering.....	<input type="checkbox"/>	<input type="checkbox"/>	<input type="checkbox"/>
Detailed operating instruction.....	<input type="checkbox"/>	<input type="checkbox"/>	<input type="checkbox"/>
Condition concrete.....	<input type="checkbox"/>	<input type="checkbox"/>	<input type="checkbox"/>
Safety device of hinge bolt.....	<input type="checkbox"/>	<input type="checkbox"/>	<input type="checkbox"/>
Condition automotive lift.....	<input type="checkbox"/>	<input type="checkbox"/>	<input type="checkbox"/>
Condition colour.....	<input type="checkbox"/>	<input type="checkbox"/>	<input type="checkbox"/>
Construction (deformation, cracking).....	<input type="checkbox"/>	<input type="checkbox"/>	<input type="checkbox"/>
Torque of the dowels (bolts).....	<input type="checkbox"/>	<input type="checkbox"/>	<input type="checkbox"/>
Torque moments of the screws.....	<input type="checkbox"/>	<input type="checkbox"/>	<input type="checkbox"/>
Condition operating unit.....	<input type="checkbox"/>	<input type="checkbox"/>	<input type="checkbox"/>
Condition surface piston rod.....	<input type="checkbox"/>	<input type="checkbox"/>	<input type="checkbox"/>
Condition coverings.....	<input type="checkbox"/>	<input type="checkbox"/>	<input type="checkbox"/>
Condition electrical wires.....	<input type="checkbox"/>	<input type="checkbox"/>	<input type="checkbox"/>
Level of hydraulic oil.....	<input type="checkbox"/>	<input type="checkbox"/>	<input type="checkbox"/>
Closeness of the hydraulic system.....	<input type="checkbox"/>	<input type="checkbox"/>	<input type="checkbox"/>
Condition hydraulic hoses.....	<input type="checkbox"/>	<input type="checkbox"/>	<input type="checkbox"/>
Function test with vehicle.....	<input type="checkbox"/>	<input type="checkbox"/>	<input type="checkbox"/>
Function safety devices.....	<input type="checkbox"/>	<input type="checkbox"/>	<input type="checkbox"/>
Condition welding.....	<input type="checkbox"/>	<input type="checkbox"/>	<input type="checkbox"/>
Condition, function mobile set.....	<input type="checkbox"/>	<input type="checkbox"/>	<input type="checkbox"/>

(mark here applicable, in case of verification mark in addition to the first mark!)

Security check carried out:.....

Carried out the company:.....

Name, address of the competent:.....

Result of the Check:

- Initiation not permitted, verification necessary
- Initiation possible, repair failures until.....
- No failings, Initiation possible

.....
signature of the expert

.....
signature of the operator

If failures must be repaired:

Failures repaired at:signature of the operator

(Use another form for verification!)

Regular security check and Maintenance

Serial-number: _____

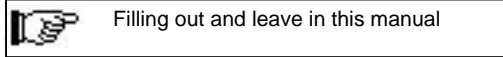

kind of check	all right	defect missing	verification	veri-remark
Type plate.....	<input type="checkbox"/>	<input type="checkbox"/>	<input type="checkbox"/>
Short operating instruction.....	<input type="checkbox"/>	<input type="checkbox"/>	<input type="checkbox"/>
Warning designation.....	<input type="checkbox"/>	<input type="checkbox"/>	<input type="checkbox"/>
Sticker "max. capacity".....	<input type="checkbox"/>	<input type="checkbox"/>	<input type="checkbox"/>
Sticker "Centre of gravity".....	<input type="checkbox"/>	<input type="checkbox"/>	<input type="checkbox"/>
Function lifting/lowering.....	<input type="checkbox"/>	<input type="checkbox"/>	<input type="checkbox"/>
Detailed operating instruction.....	<input type="checkbox"/>	<input type="checkbox"/>	<input type="checkbox"/>
Condition concrete.....	<input type="checkbox"/>	<input type="checkbox"/>	<input type="checkbox"/>
Safety device of hinge bolt.....	<input type="checkbox"/>	<input type="checkbox"/>	<input type="checkbox"/>
Condition automotive lift.....	<input type="checkbox"/>	<input type="checkbox"/>	<input type="checkbox"/>
Condition colour.....	<input type="checkbox"/>	<input type="checkbox"/>	<input type="checkbox"/>
Construction (deformation, cracking).....	<input type="checkbox"/>	<input type="checkbox"/>	<input type="checkbox"/>
Torque of the dowels (bolts).....	<input type="checkbox"/>	<input type="checkbox"/>	<input type="checkbox"/>
Torque moments of the screws.....	<input type="checkbox"/>	<input type="checkbox"/>	<input type="checkbox"/>
Condition operating unit.....	<input type="checkbox"/>	<input type="checkbox"/>	<input type="checkbox"/>
Condition surface piston rod.....	<input type="checkbox"/>	<input type="checkbox"/>	<input type="checkbox"/>
Condition coverings.....	<input type="checkbox"/>	<input type="checkbox"/>	<input type="checkbox"/>
Condition electrical wires.....	<input type="checkbox"/>	<input type="checkbox"/>	<input type="checkbox"/>
Level of hydraulic oil.....	<input type="checkbox"/>	<input type="checkbox"/>	<input type="checkbox"/>
Closeness of the hydraulic system.....	<input type="checkbox"/>	<input type="checkbox"/>	<input type="checkbox"/>
Condition hydraulic hoses.....	<input type="checkbox"/>	<input type="checkbox"/>	<input type="checkbox"/>
Function test with vehicle.....	<input type="checkbox"/>	<input type="checkbox"/>	<input type="checkbox"/>
Function safety devices.....	<input type="checkbox"/>	<input type="checkbox"/>	<input type="checkbox"/>
Condition welding.....	<input type="checkbox"/>	<input type="checkbox"/>	<input type="checkbox"/>
Condition, function mobile set.....	<input type="checkbox"/>	<input type="checkbox"/>	<input type="checkbox"/>

(mark here applicable, in case of verification mark in addition to the first mark!)

Security check carried out:.....

Carried out the company:.....

Name, address of the competent:.....

Result of the Check:

- Initiation not permitted, verification necessary
- Initiation possible, repair failures until.....
- No failings, Initiation possible

.....
signature of the expert

.....
signature of the operator

If failures must be repaired:

Failures repaired at:signature of the operator

(Use another form for verification!)

Extraordinary security check

Serial-number: _____



Filling out and leave in this manual

kind of check	all right	defect missing	verifi- fication	ver- remark
Type plate.....	<input type="checkbox"/>	<input type="checkbox"/>	<input type="checkbox"/>
Short operating instruction.....	<input type="checkbox"/>	<input type="checkbox"/>	<input type="checkbox"/>
Warning designation.....	<input type="checkbox"/>	<input type="checkbox"/>	<input type="checkbox"/>
Sticker "max. capacity".....	<input type="checkbox"/>	<input type="checkbox"/>	<input type="checkbox"/>
Sticker "Centre of gravity".....	<input type="checkbox"/>	<input type="checkbox"/>	<input type="checkbox"/>
Function lifting/lowering.....	<input type="checkbox"/>	<input type="checkbox"/>	<input type="checkbox"/>
Detailed operating instruction.....	<input type="checkbox"/>	<input type="checkbox"/>	<input type="checkbox"/>
Condition concrete.....	<input type="checkbox"/>	<input type="checkbox"/>	<input type="checkbox"/>
Safety device of hinge bolt.....	<input type="checkbox"/>	<input type="checkbox"/>	<input type="checkbox"/>
Condition automotive lift.....	<input type="checkbox"/>	<input type="checkbox"/>	<input type="checkbox"/>
Condition colour.....	<input type="checkbox"/>	<input type="checkbox"/>	<input type="checkbox"/>
Construction (deformation, cracking)	<input type="checkbox"/>	<input type="checkbox"/>	<input type="checkbox"/>
Torque of the dowels (bolts).....	<input type="checkbox"/>	<input type="checkbox"/>	<input type="checkbox"/>
Torque moments of the screws	<input type="checkbox"/>	<input type="checkbox"/>	<input type="checkbox"/>
Condition operating unit.....	<input type="checkbox"/>	<input type="checkbox"/>	<input type="checkbox"/>
Condition surface piston rod	<input type="checkbox"/>	<input type="checkbox"/>	<input type="checkbox"/>
Condition coverings.....	<input type="checkbox"/>	<input type="checkbox"/>	<input type="checkbox"/>
Condition electrical wires	<input type="checkbox"/>	<input type="checkbox"/>	<input type="checkbox"/>
Level of hydraulic oil	<input type="checkbox"/>	<input type="checkbox"/>	<input type="checkbox"/>
Closeness of the hydraulic system.....	<input type="checkbox"/>	<input type="checkbox"/>	<input type="checkbox"/>
Condition hydraulic hoses.....	<input type="checkbox"/>	<input type="checkbox"/>	<input type="checkbox"/>
Function test with vehicle.....	<input type="checkbox"/>	<input type="checkbox"/>	<input type="checkbox"/>
Function safety devices.....	<input type="checkbox"/>	<input type="checkbox"/>	<input type="checkbox"/>
Condition welding.....	<input type="checkbox"/>	<input type="checkbox"/>	<input type="checkbox"/>
Condition, function mobile set.....	<input type="checkbox"/>	<input type="checkbox"/>	<input type="checkbox"/>

(mark here applicable, in case of verification mark in addition to the first mark!)

Security check carried out:.....

Carried out the company:.....

Name, address of the competent:.....

Result of the Check:

- Initiation not permitted, verification necessary
- Initiation possible, repair failures until.....
- No failings, Initiation possible

.....
signature of the expert

.....
signature of the operator

If failures must be repaired:

Failures repaired at:signature of the operator

(Use another form for verification!)