

**Bristleflex Instructions from Martin MacGregor, <https://www.macgregorukcarparts.com>
Written by Stephen Hutchins**

The instructions Martin gave me were verbal, and with a bit of a demonstration holding the Bristleflex itself. I'll try to cover the the crucial points and I've attached a couple of drawings to try and help explain the orientation of things.

Anyway, the first important thing is that the channel with the steel claws doesn't go over both

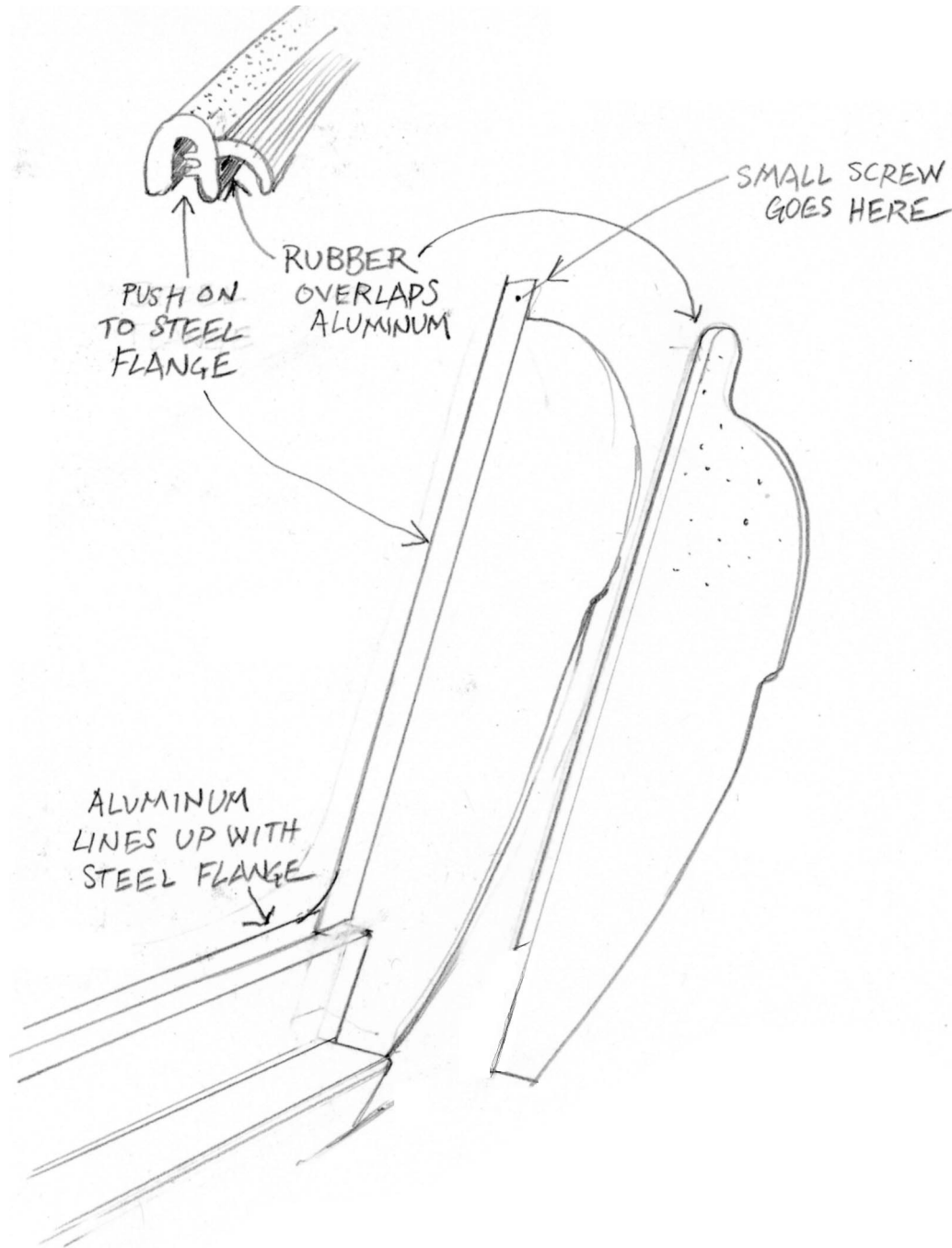

the steel flange on the car and the aluminum shut plate piece. It is pushed onto the upright steel flange only, but the Bristleflex is made so that the rubber flap on the outside overlaps the aluminum. This means you have to have some space between the aluminum and the steel. A lot of people have pushed these together and pushed the weatherstrip over the two.

When it gets to the top of the door opening and has to turn a sharp angle to go over the upholstered quarter panel, there is a small hole in the top of the steel flange. You are supposed to put a small screw, from the inside, through the weatherstripping here and into the hole to hold it in place at the bend. I found it a bit tedious getting the screw in place - you may want to use one that is a bit longer than you'd really think necessary, so that you can feed it through more easily. I forget what number the screw was, but something like the size you're using on the aluminum trim.

Then at the top of the quarter panel, there is the chrome clip that fixes the weatherstrip to the panel.

At the bottom the Bristleflex is pushed over rocker panel aluminum trim, which should line up with the bottom of the steel flange, and along towards the front, and up the forward steel edge of the door opening and stops just before the dash.

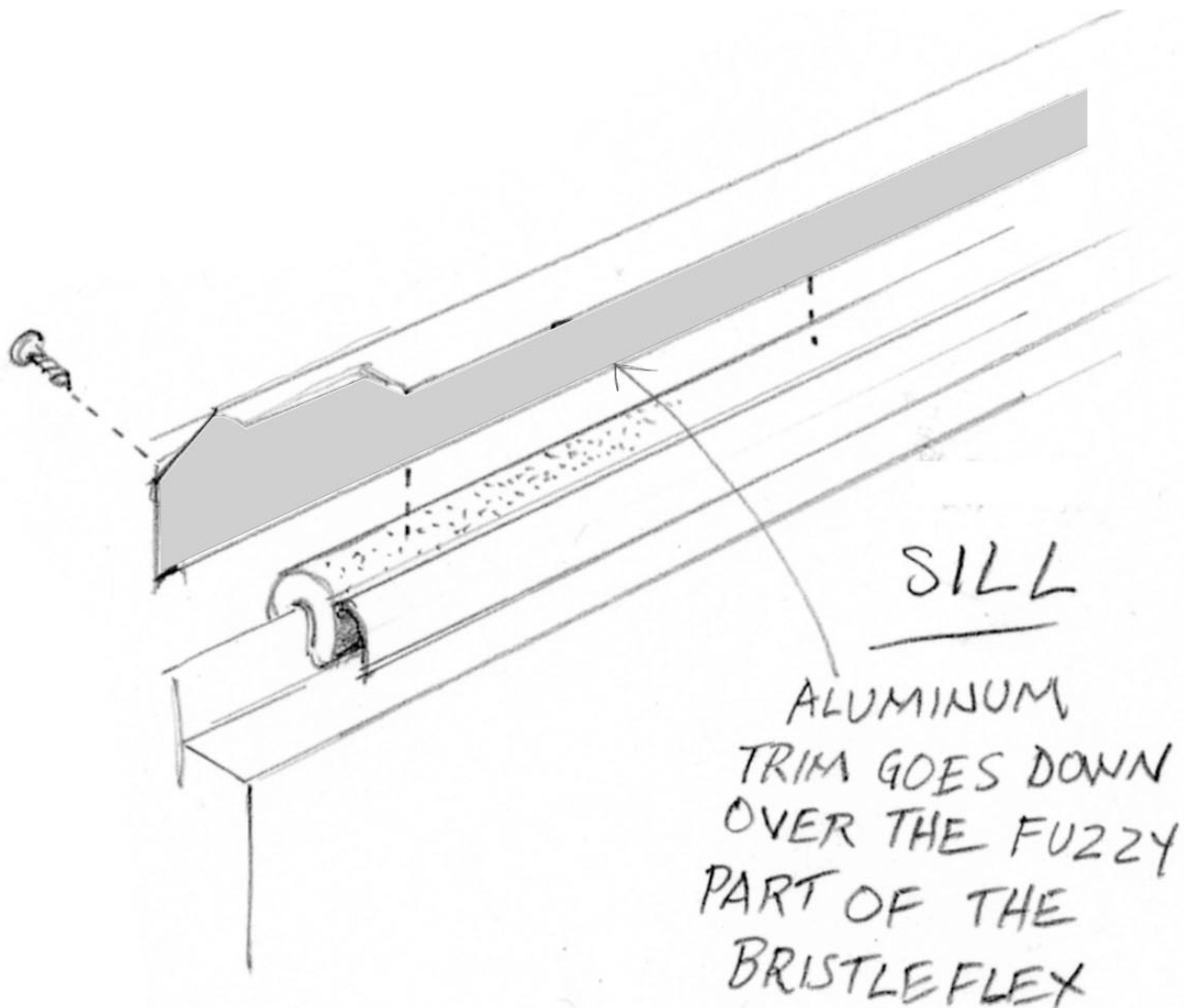

The other important thing is the way the aluminum sill trim goes on. It is screwed to the inner sill from the inside, but the top of the aluminum sill trim has to go down over the fuzzy part of the bristle flex. This holds it down and prevents you from kicking it off as you get in and out of the car.