

Some faultfinding ideas for the electrical system of 3000 overdrives.

(1)

Austin-Healey Overdrive Wiring. BN2 & up

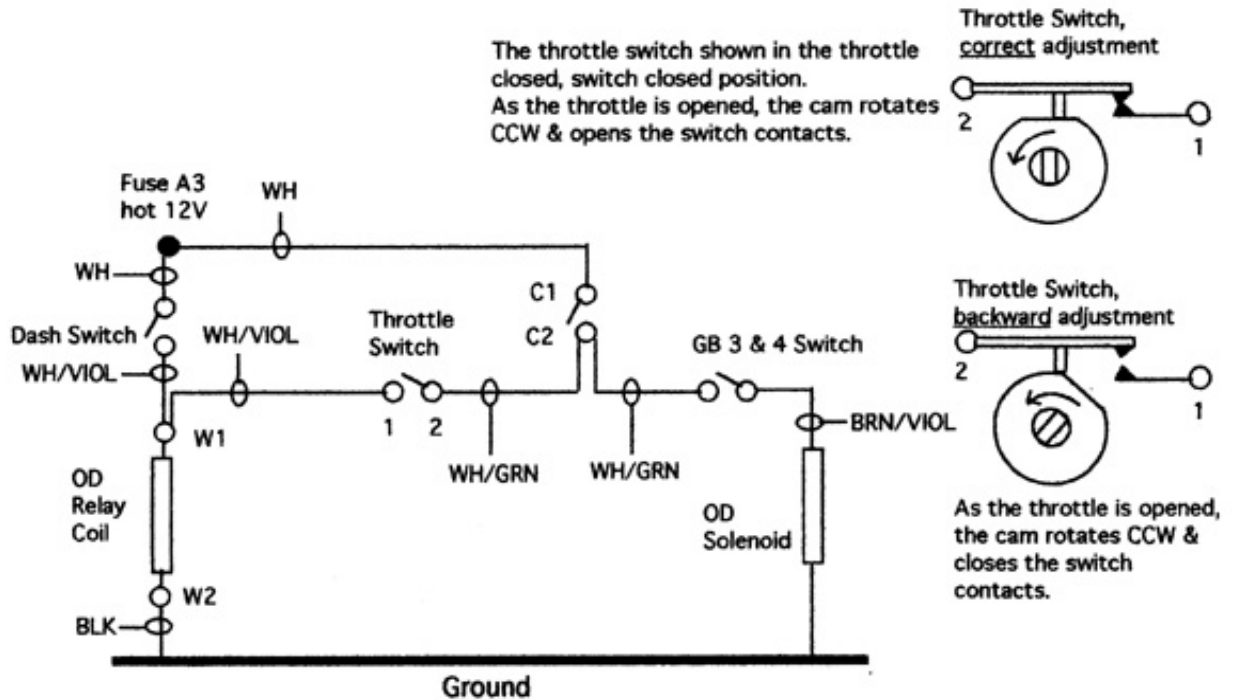

The throttle switch is intended to prevent an OD downshift with the throttle closed which would cause a jerk on the drivetrain.

The throttle switch should be adjusted so that its contact is closed only when the throttle position is from closed to about 25% open. This can be done by loosening its arm clamp & turning the slotted shaft a bit. On most switches the slot will be nearly vertical. I have read of some replacement switches having the slot horizontal as normal. Turning the shaft more CW as viewed from the shaft side will increase the amount of throttle opening that is required to allow a downshift.

When dash switch is operated the OD relay operates & closes its C1 to C2 contact.

C1 to C2 closure applies 12 volts through the gearbox 3rd & 4th gear contact to the OD solenoid which energizes.

If the GB 3-4 contact opens by shifting to any other gear, the solenoid deenergizes.

If the dash switch is turned off with the throttle switch closed, the relay deenergizes & the C1 - C2 contact opens but it is bypassed by the throttle switch & the OD solenoid remains operated.

When the throttle is depressed the throttle switch opens & deenergizes the solenoid.

By DGR
3/8/04
Rev. 5/14/04

(2) I am sure that most Healey owners have had problems with their overdrives at some stage. I certainly have, although I keep it topped up with clean oil and otherwise leave it alone. Sadly, Lucas electrics always were a trifle frail and, it seems, the modern replacements are even frailer. So, problems do crop up....

I know a little about 3000 overdrives – all learnt from other people – and I know **nothing** about 100 and 100/6 units, though I gather that they are very similar to 3000s.

Firstly, when there is a problem, you cannot go wrong by immediately checking the oil level. The gearbox oil circulates through the overdrive and, if there is insufficient oil available to the unit's pump, there will not be enough pressure to engage overdrive or, as can happen in hotter conditions, keep it engaged.

Secondly, given enough clean oil, most problems are electrical. Happily, they are the easiest to diagnose and fix. On this subject, it is my belief that, if one can bully the unit into working by electrical experimentation – bridging some points for example – then the problem **has** to be electrical. This may seem obvious when printed, but it is surprising how often people make the wrong assumptions.

(3) The problem that started me off on this learning curve was seemingly quite simple. Cruising along at about 1,900 rpm in 4th gear with overdrive engaged I would find that overdrive disengaged when I accelerated and would then reengage as I slowed down. This was irritating and made overtaking more exciting than necessary.

(4) It seemed to me then that the problem just **must** be in the throttle switch, but I knew that it remained correctly adjusted as before and that I'd not touched any other relevant settings – the accelerator linkage on the bulkhead for example. So, I elected to seek help and research the whole issue before ripping everything apart and, worse yet, haphazardly replacing the electrics item by item.

(5) I requested help and advice on the internet and received a lot of mail including a couple of jewels. The wiring diagram, above, is, in my opinion, much more useful than those in the workshop manuals and the accompanying text is most helpful. My thanks to Dave Russell for his permission to reproduce it here. You will see that it mentions “BN2 & up”. I have never even seen a BN2 overdrive, so cannot comment.

I also received a copy of an article written for the Cascade Austin Healey Club. Its author, Bob Poague, gave me permission to reproduce it here. I have fractionally reduced it:--

(6)

““““THE OVERDRIVE ELECTRICAL SYSTEM

The design of the electrical circuit that controls the Overdrive in Austin-Healeys is such that unrecognized or undiagnosed faults can exist which, though not serious enough to disable the Overdrive, may prevent it from functioning fully as intended. Typical symptoms can include unwanted, unexpected, or unexplained engagements or disengagements of the Overdrive, particularly if they are related to throttle position, and are *crisp*. Engagements or disengagements that are *sluggish*, with excess delay or noticeable slipping, suggest mechanical and/or hydraulic problems.

(a) My intention is to clarify the throttle switch function and to describe a simple test that can be applied to check out not only the throttle switch but the rest of the overdrive electrical system as well. It assumes that the overdrive hydraulic system is OK, but not necessarily that the overdrive is working properly overall. Emphasis is on the diagnosis of possible faults, rather than on repair, though the latter would usually be fairly straight forward.

The article is specifically directed to the later four cylinder and six cylinder cars, though should also be helpful for the early four cylinder models, whose circuit design is somewhat different.

Contrary to some views, the throttle switch, located on the firewall, and connected to the throttle mechanism by a rod, is not intended to act as a “kickdown” device as in some other cars. However, if it is not properly adjusted, or if another component in the circuit is faulty, it can indeed produce similar results. This should not obscure the fact that it was not designed to do so.

According to official Austin Healey workshop manuals: “If effected with closed throttle, a change from overdrive to direct drive could result in a shock to the transmission. An interlocking circuit is therefore incorporated to override the dash-mounted toggle switch under closed throttle conditions. Under these conditions, the firewall-mounted throttle switch contacts provide an alternative supply circuit to the firewall-mounted relay operating coil.” In other words, the throttle switch is intended to prevent you from disengaging the overdrive when your foot is off the throttle, rather than to enable you to disengage by flooring the throttle.

You can perform a simple test of your car’s system without even starting the engine by following the steps listed below. The test relies on the fact that engagement of the overdrive solenoid is very audible, though disengagement is less so.

(The term “wiggle” appears in some of the steps. This means having the transmission in neutral and moving the gearshift lever right and left so that it engages and disengages the electric 3rd & 4th gear switch, which, when the gearshift lever is to your right, allows you to engage overdrive in the top two gears only.)

(b) The test:

1. Make sure battery switch is ON and battery is charged.
2. Make sure overdrive dash switch is in OFF position.
3. Turn ignition switch ON (but don’t start the engine).
4. Keep your foot off the throttle.
5. Wiggle the gearshift, making sure you move it fully to the right each time. You should not hear the solenoid actuate. (If you do, see Note 1.)
6. Move overdrive dash switch to ON position.
7. Wiggle the gearshift - you should hear the solenoid engage and disengage with each wiggle. (If you don’t, see Note 2.)
8. Depress the throttle about ½ way and hold. Wiggle the gearshift - you should still hear the solenoid engage and disengage with each wiggle. (If you don’t, see Note 3.)
9. Take your foot off the throttle. Move the overdrive dash switch to OFF. Wiggle the gearshift - you should still hear the solenoid engage and disengage with each wiggle. (If you don’t, see Note 4.)
10. Slowly start depressing the throttle while wiggling the gearshift at the same time. You should initially hear the solenoid engage and disengage until the throttle reaches approximately 1/5 open position (workshop manual spec.). Then, while continuing to wiggle, you should not hear the solenoid regardless of the throttle position. (If you do, see Note 5.)

If your car passes this test, your overdrive electrical system is OK. If not, the following notes, related to the Steps above, may be helpful.

(c) Note 1. First, start over, repeating Steps 1 through 4. If you get the same results, it means your solenoid is getting voltage, through the gearshift switch, from some direct means other than through the dash switch, relay, and/or throttle switch. Operational symptoms would be that you would be in overdrive anytime you were in either of the top two gears, regardless of the position of the dash switch. Very unlikely, but if so, check your wiring carefully.

Note 2. First, make sure you have the battery switch ON, a good battery, ignition ON, dash overdrive switch ON, are moving the gearshift lever completely to the right (in the neutral “gate”) each time, and are listening carefully. If you still don’t hear anything, and particularly if your overdrive hasn’t been working, you have a definite problem in your system. The overdrive circuit isn’t fused, so forget that. The problem could be in the wiring or any of the switches involved. Diagnosis exceeds the scope of this article. *(Check all the wiring connections, then the solenoid, then the relay; then by-pass the throttle switch if either of the previous two give any joy. Simon.)*

Note 3. Try different throttle positions, from fully closed to fully open. If the solenoid actuates in some throttle positions but not others, it’s most likely that the firewall-mounted relay is faulty, and that the solenoid is receiving voltage only through the throttle switch, which may have been misadjusted to compensate. Check out the relay and associated wiring. Since you apparently passed Step 6, you know that, at least under some conditions, you are getting voltage to the solenoid. *(You can easily test the relay. See below. Simon.)*

Note 4. Failure of this Step, assuming previous Steps passed, means your throttle switch is either faulty or misadjusted, or that its associated wiring is faulty. It is not properly by-passing the dash switch to keep the relay energized when the throttle is closed. Operational symptoms would be that the overdrive disengages whenever you turn the dash switch off, even at closed throttle. The throttle switch should be closed (allowing current to flow through it) when the throttle is between closed and approximately 1/5 open positions. It should open beyond 1/5 throttle open position. (Remember its purpose, which is to prevent overdrive disengagement, via the dash switch, at road speeds while coasting, throttle closed, thus avoiding shock to the gearbox and gear train.)

Note 5. First, re-run the entire test - you may have inadvertently pressed the throttle too fast while wiggling the gear lever. Assuming you passed all previous Steps, failure of this Step will most likely be due to a misadjusted throttle switch. A remote possibility would be an internal short in the switch or its associated wiring. Operational symptoms might be that after turning the dash switch off, the overdrive won’t disengage unless the throttle is opened well beyond the 1/5 to 1/4 position, or unless the ignition is switched off.

(d) Adjustment of the throttle switch is mostly a trial-and-error affair. It is best accomplished with the aid of a voltmeter or test light, but can certainly be done without those via an understanding and following of the test Steps listed earlier. Determination of “1/5 open throttle” is, I believe, very subjective and hard to measure, given the variety of carburetor models involved. I would submit that it corresponds to the throttle position that produces a steady speed of about 20 MPH in top gear overdrive on a level road. Under those conditions, your overdrive should not disengage when the dash switch is turned off, but should disengage under the same conditions if the speed were, say, 15 MPH.””””(end of article).

(To test the relay... Operation of the relay coil can be checked by applying 12 volts to terminals W1 & W2. If the coil operates, there should be solid continuity between terminals C1 & C2. The relay itself can be opened by removing its cover. The contacts can be carefully cleaned. Or the relay itself may be defective & not repairable).

(7) So, armed with the above (especially **note 3**), I determined that my relay was probably not working. It seemed that current was not passing through the relay to the solenoid, but that it was passing via the throttle switch. Remember that – to put it crudely - the relay and throttle switch are connected to the solenoid (via the 3rd & 4th switch!) in parallel and that the throttle switch points remain closed until the accelerator is depressed beyond the magic +/- 25%. Thus, my throttle switch was doing what it was designed to do by opening at 25%, but in so doing it deprived the solenoid of power and switched the car out of overdrive! I was able to test this by bypassing the points in the throttle switch (shorting its two wires). This gave a permanent feed to the solenoid that was controlled by the dash on/off. This pointed the finger even further at the relay which I then tested with a meter. It failed. Replacement cured the problem.

(8) After a previous skirmish, I installed an inline fuse to protect the circuitry. There is enough power available to fry most of the components, especially the solenoid and none of them are cheap. This is a very simple step and well worth the twenty minutes taken.

A quick note of caution....it is rash to by pass the 3rd & 4th switch for anything other than electrical fault finding. Engaging and using reverse gear with the overdrive engaged can turn your overdrive into scrap.

Simon Lachlan, June '04.